

STATE OF NORTH CAROLINA  
DEPARTMENT OF TRANSPORTATION  
HIGHWAY DIVISION 6

# PLANS

**Letting Date: SEPTEMBER 18, 2024**

**CONTRACT ID: DF00493**

**TIP NO.: BO-2406A**

**FEDERAL AID NO.: 5093503**

**WBS ELEMENT NO.: 50935.3.3**

**ROUTE NO.: VARIOUS**

**LOCATION: VARIOUS**

**COUNTY: BLADEN, COLUMBUS, CUMBERLAND, HARNETT & ROBESON**

**LENGTH OF PROJECT: VARIES**

**TYPE OF WORK: CONCRETE INSTALLATIONS**

**This electronic collection of documents is provided  
for the convenience of the user  
and is Not a Certified Document –**

**The documents contained herein were originally issued  
and sealed by the individuals whose names and license  
numbers appear on each page, on the dates appearing  
with their signature on that page.**

**This file or an individual page  
shall not be considered a certified document.**



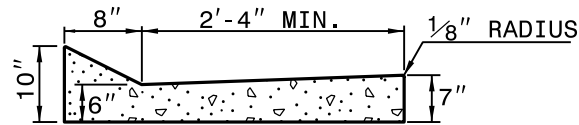
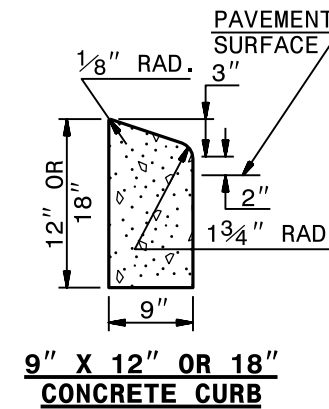
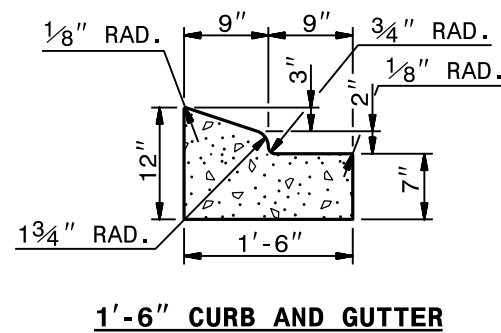
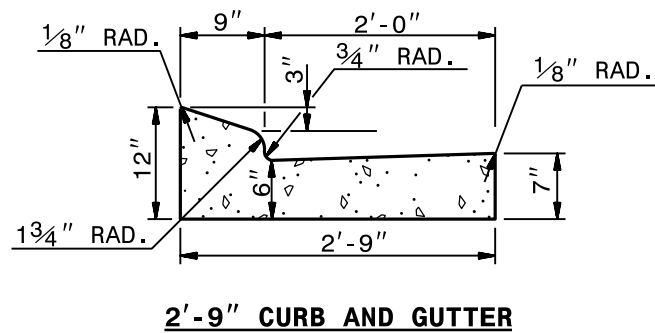
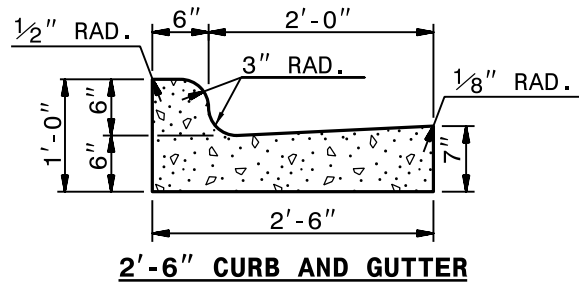

**SHOULDER BERM GUTTER**

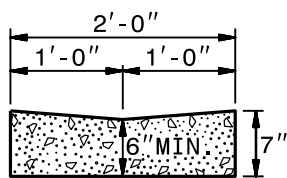

**VALLEY GUTTER**

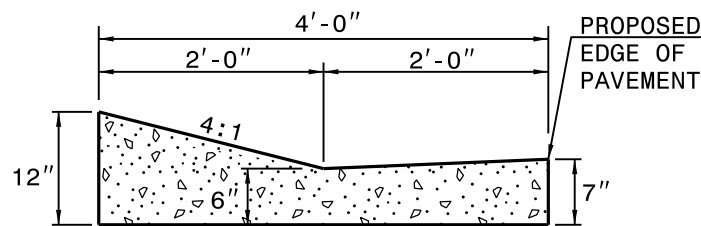

**EXPRESSWAY GUTTER**

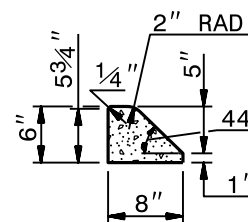

**8\"/>**

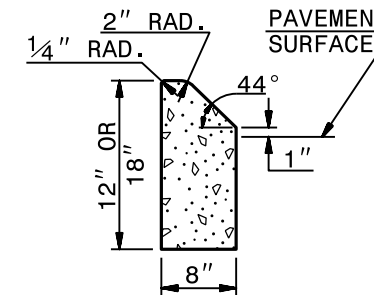

**8\"/>**

**SECTION VIEW OF CURBS OR CURBS AND GUTTERS**

**GENERAL NOTES:**

- PLACE CONTRACTION JOINTS AT 10' INTERVALS, EXCEPT THAT A 15' SPACING MAY BE USED WHEN A MACHINE IS USED OR WHEN SATISFACTORY SUPPORT FOR THE FACE FORM CAN BE OBTAINED WITHOUT THE USE OF TEMPLATES AT 10' INTERVALS.
- JOINT SPACING MAY BE ALTERED IF REQUIRED BY THE ENGINEER.
- CONTRACTION JOINTS MAY BE INSTALLED WITH THE USE OF TEMPLATES OR FORMED BY OTHER APPROVED METHODS.
- CONSTRUCT NON-TEMPLATE FORMED JOINTS A MIN. OF 1½" DEEP.
- FILL ALL CONSTRUCTION JOINTS, EXCEPT IN 8"x6" MEDIAN CURB, WITH JOINT FILLER AND SEALER.
- SPACE EXPANSION JOINTS AT 90' INTERVALS AND ADJACENT TO ALL RIGID OBJECTS.

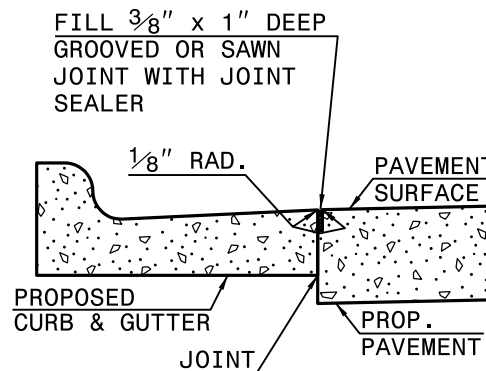

**LONGITUDINAL JOINT**

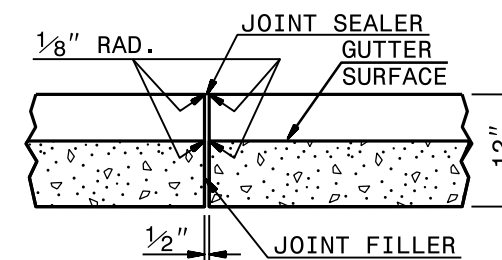

**TRANSVERSE EXPANSION JOINT  
IN CURB AND GUTTER**

**SECTION VIEW OF JOINTS**

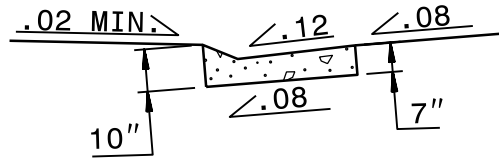
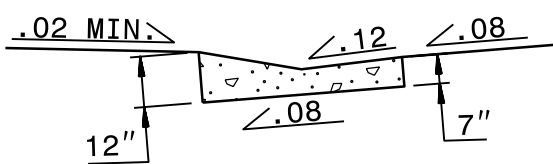
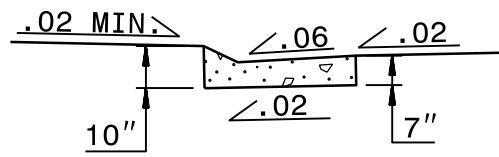
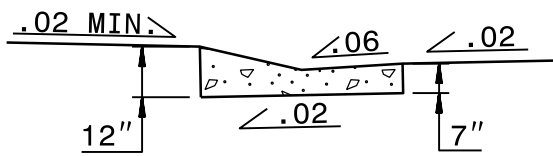
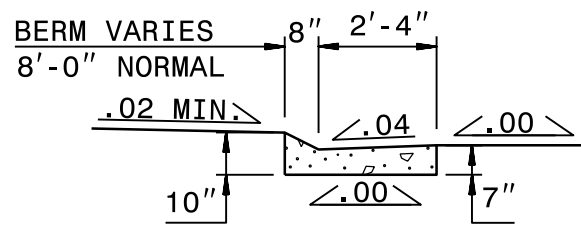
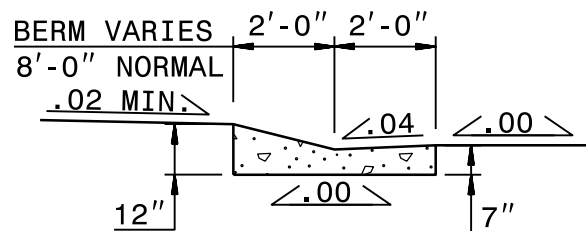
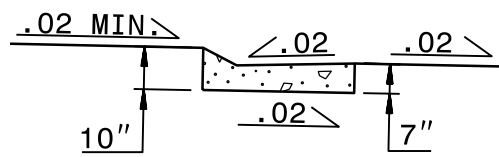
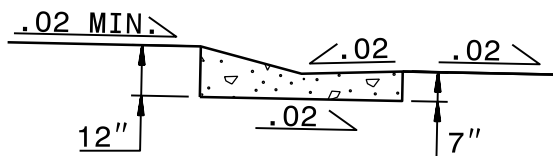
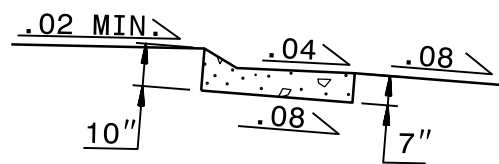
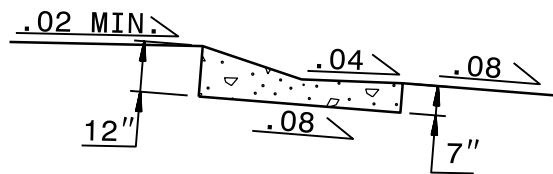

EXPRESSWAY GUTTER

SHOULDER BERM GUTTER

**SECTION VIEWS OF EXPRESSWAY GUTTER AND SHOULDER BERM GUTTER SUPERELEVATION RATES**

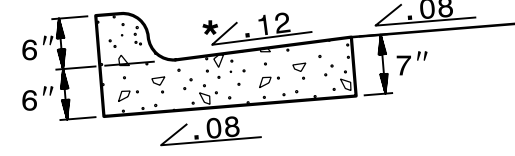
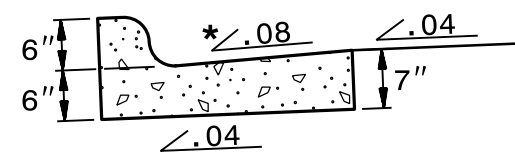
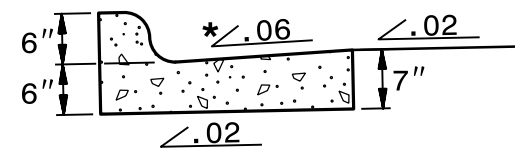
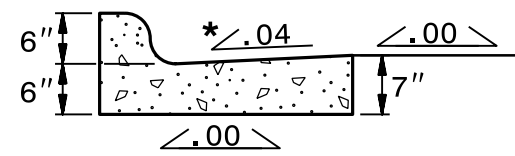
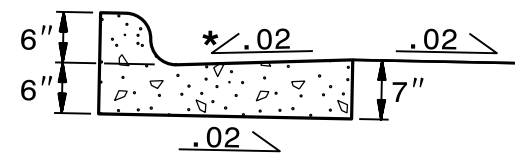
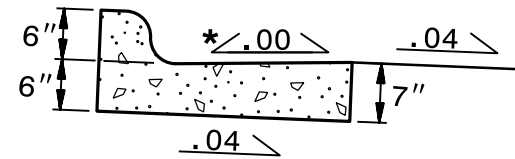

\* THE GUTTER SLOPE FOR 1'-6" CURB AND GUTTER SHALL MATCH THE SLOPE OF THE ADJOINING PAVEMENT.

**SECTION VIEWS OF 1'-6", 2'-6" (DEPICTED) AND 2'-9" CURB AND GUTTER SUPERELEVATION RATES**

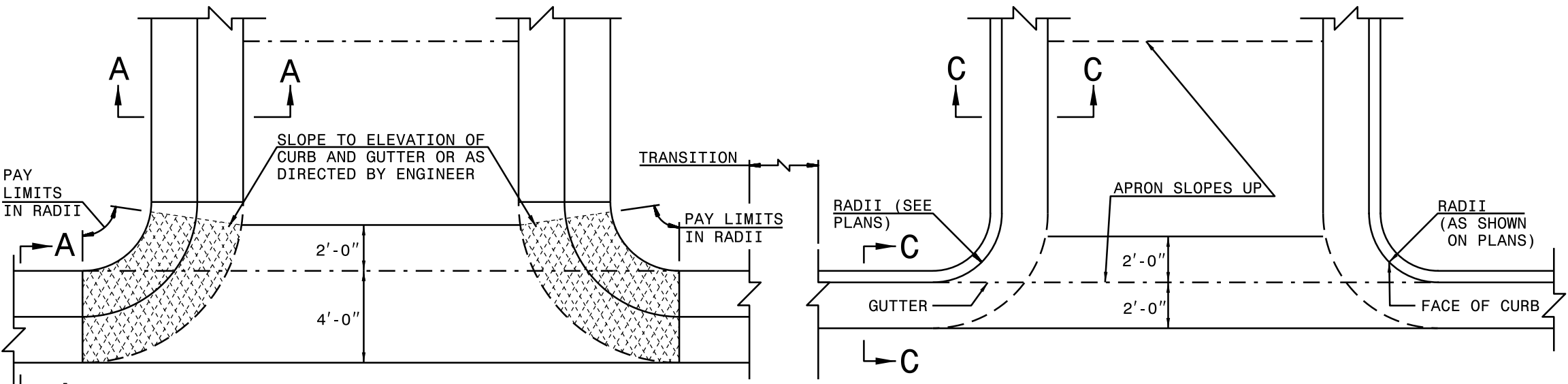

DRIVEWAY WITH EXPRESSWAY GUTTER      TRANSITION      DRIVEWAY WITH 2'-6" CURB AND GUTTER

**PLAN VIEW OF TYPICAL CURB AND GUTTER OCCURENCES**

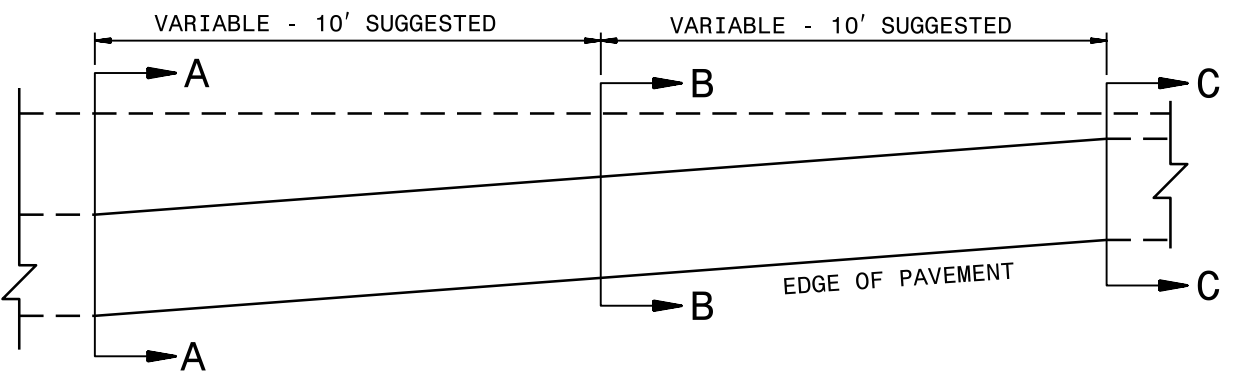

**PLAN VIEW OF TRANSITION  
EXPRESSWAY GUTTER TO 2'-6" CURB AND GUTTER**

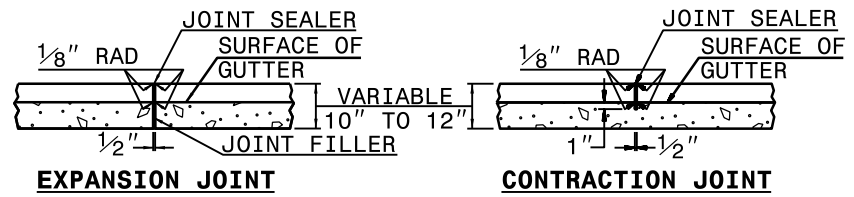
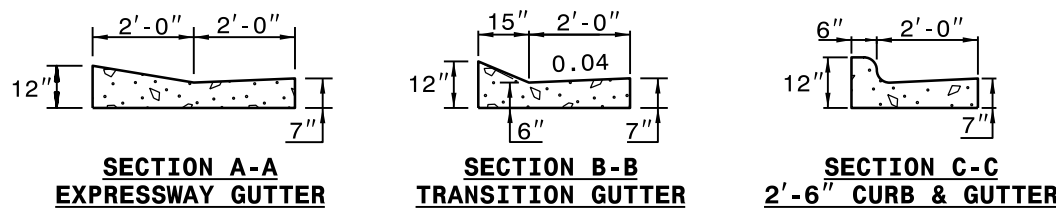

- NOTES:**
- IN THE TRANSITION FROM 4'-0" CONCRETE EXPRESSWAY GUTTER TO 2'-6" CONCRETE CURB AND GUTTER, PLACE 1/2" EXPANSION JOINTS AT 25' INTERVALS.
  - PLACE GROOVE JOINTS 1" DEEP AT 12'-6" INTERVALS BETWEEN EXPANSION JOINTS.
  - FILL AND SEAL THE TOP 1/2" OF THE EXPANSION JOINTS AND 1" OF CONTRACTION JOINTS WITH APPROVED JOINT SEALING COMPOUND.

NOTES:

CONSTRUCT STANDARD SIDEWALK 5' WIDE AND 4" THICK UNLESS OTHERWISE DENOTED ON PLANS.

PLACE A GROOVE JOINT 1" DEEP WITH  $\frac{1}{8}$ " RADII IN THE CONCRETE SIDEWALK AT 5' INTERVALS. ONE  $\frac{1}{2}$ " EXPANSION JOINT WILL BE REQUIRED AT 50' INTERVALS. A  $\frac{1}{2}$ " EXPANSION JOINT WILL BE REQUIRED WHERE THE SIDEWALK JOINS ANY RIGID STRUCTURE.

SEE STD. DWG. 848.05 FOR CURB RAMP LOCATION REQUIREMENTS AND CONSTRUCTION GUIDELINES.

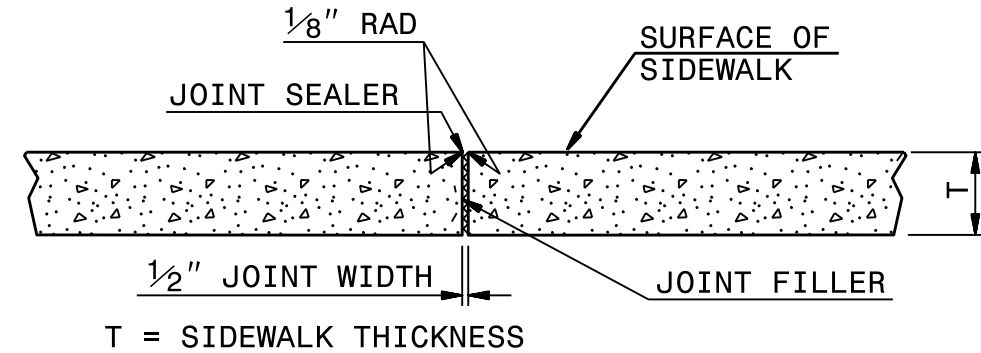

TRANSVERSE EXPANSION JOINT  
IN SIDEWALK

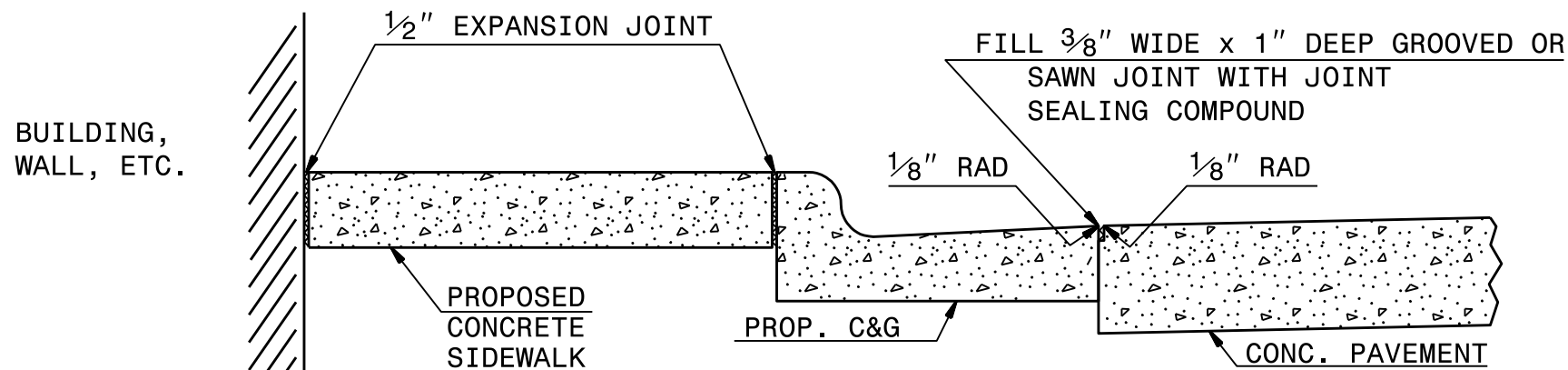

DETAILS SHOWING JOINTS IN CONCRETE SIDEWALK

\* SIDEWALK TAPERS DOWN  
5' BACK FROM DRIVEWAY.

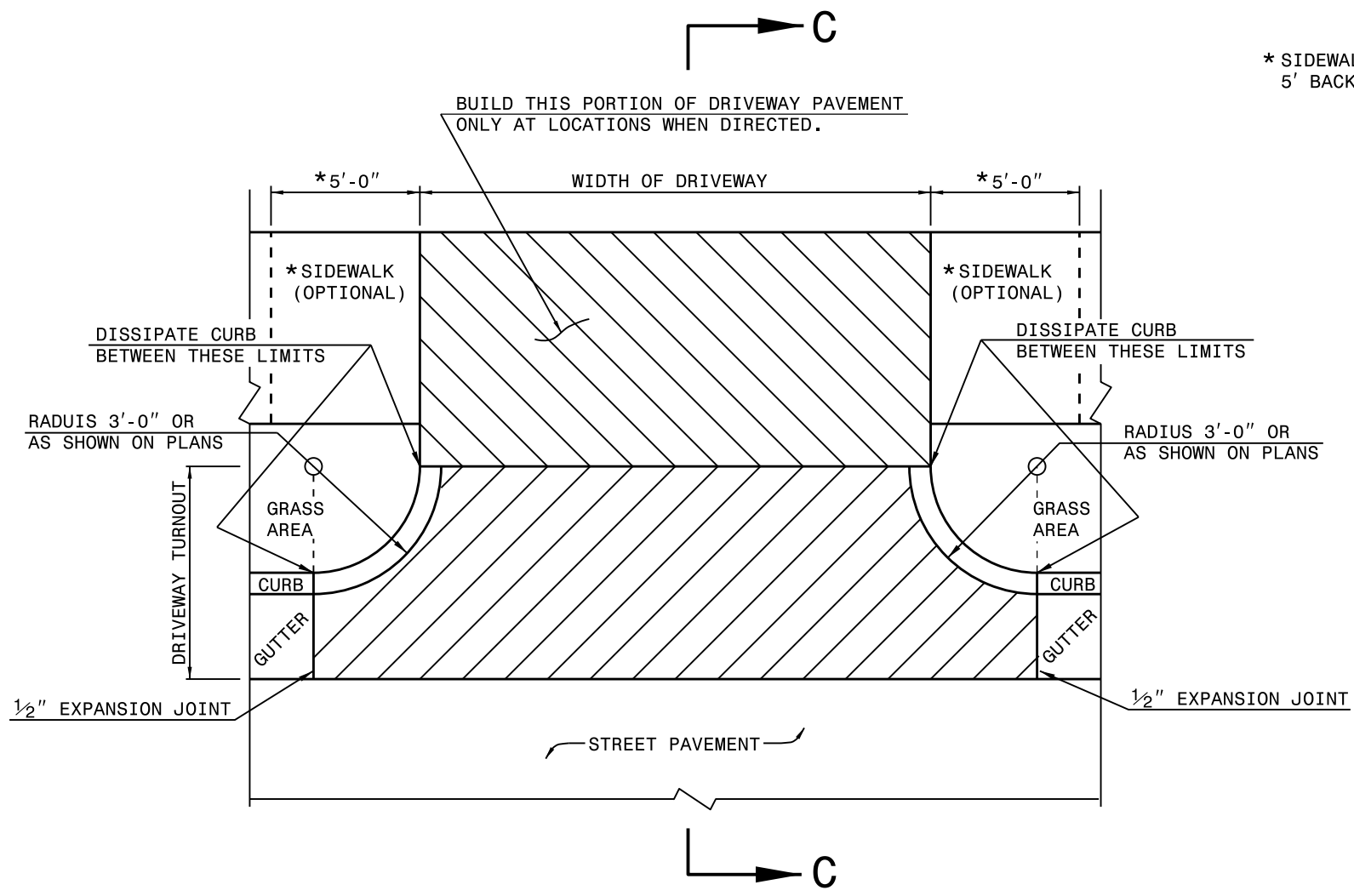

**PLAN  
DETAIL OF DRIVEWAY**

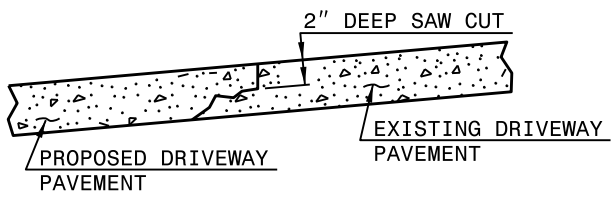

**METHOD OF TIE IN**

WHEN EXISTING DRIVEWAY PAVEMENT IS CONCRETE,  
SAW CUT 2" DEEP JOINT AT THE POINT OF TIE-IN.  
SAW JOINT PERPENDICULAR TO EDGE OF EXISTING  
DRIVEWAY PAVEMENT.

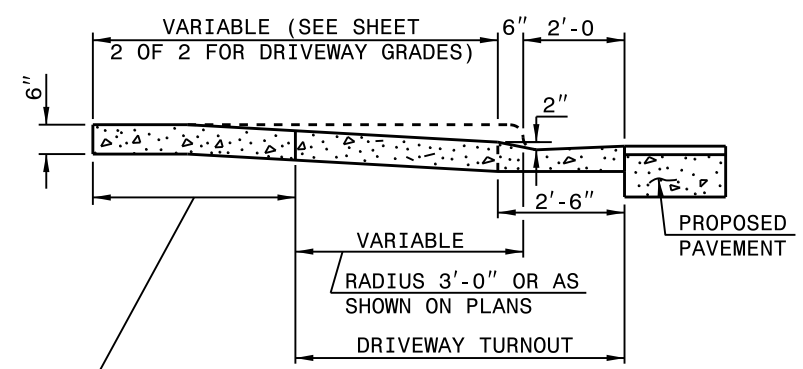

BUILD THIS PORTION OF DRIVEWAY  
PAVEMENT ONLY AT LOCATIONS  
WHEN DIRECTED.

**SECTION C-C**



### DESIRABLE DRIVEWAY GRADES

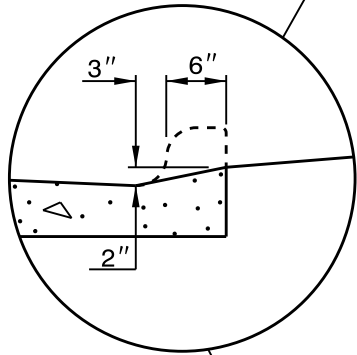
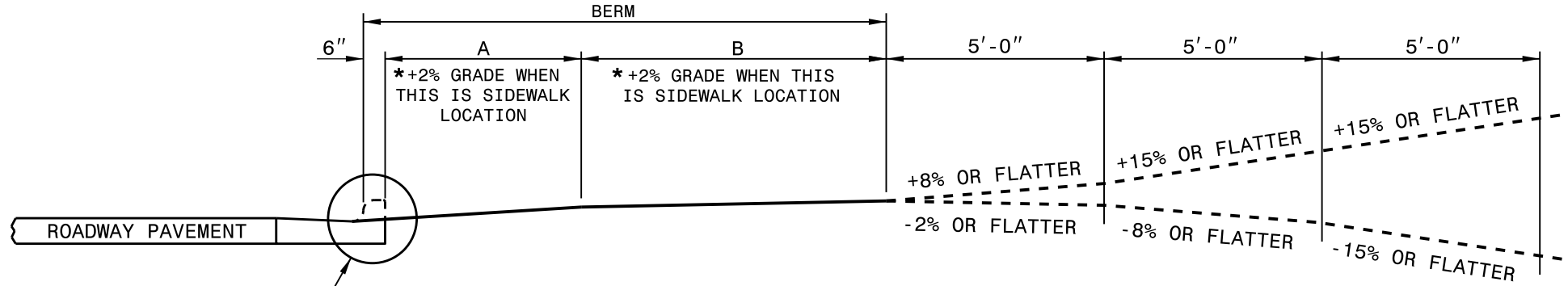

\*SIDEWALK LOCATION  
(DO NOT PLACE SIDEWALK ON  
BERMS LESS THAN 6' WIDE.)

DESIRABLE OR MAXIMUM DRIVEWAY GRADES				
BERM WIDTH	A		B	
	DIST.	GRADE	DIST.	GRADE
8' OR LESS	5'-0"	+2%*	2'-6"	+5%
8' OR LESS	2'-0"	+6%	5'-6"	+2%*
10'	4'-0"	+4%	5'-6"	+2%*
12' & OVER	4'-6"	+4%	7'-0"	+2%*

### MAXIMUM DRIVEWAY GRADES

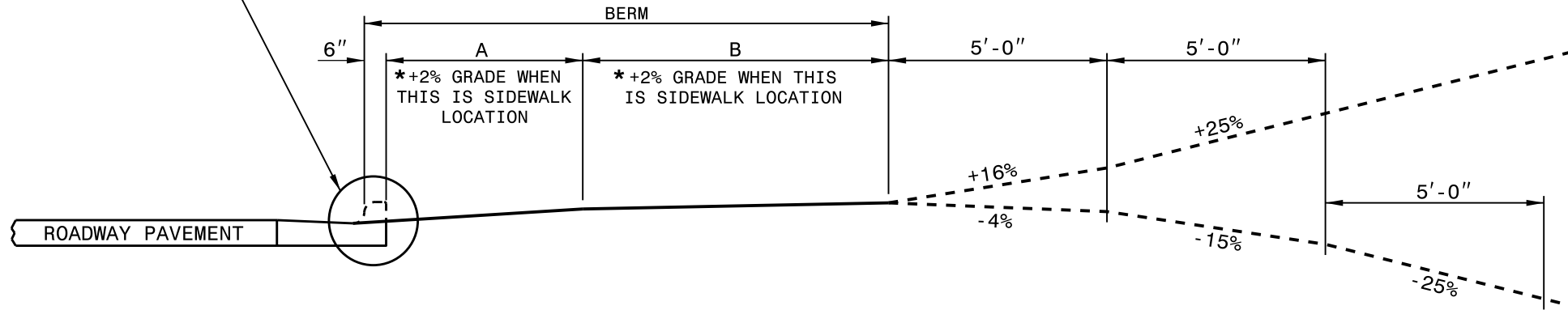

1-24

ROADWAY STANDARD DRAWING FOR  
**DRIVEWAY TURNOUT**  
DROP CURB TYPE

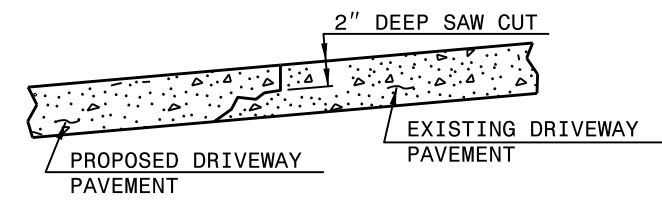
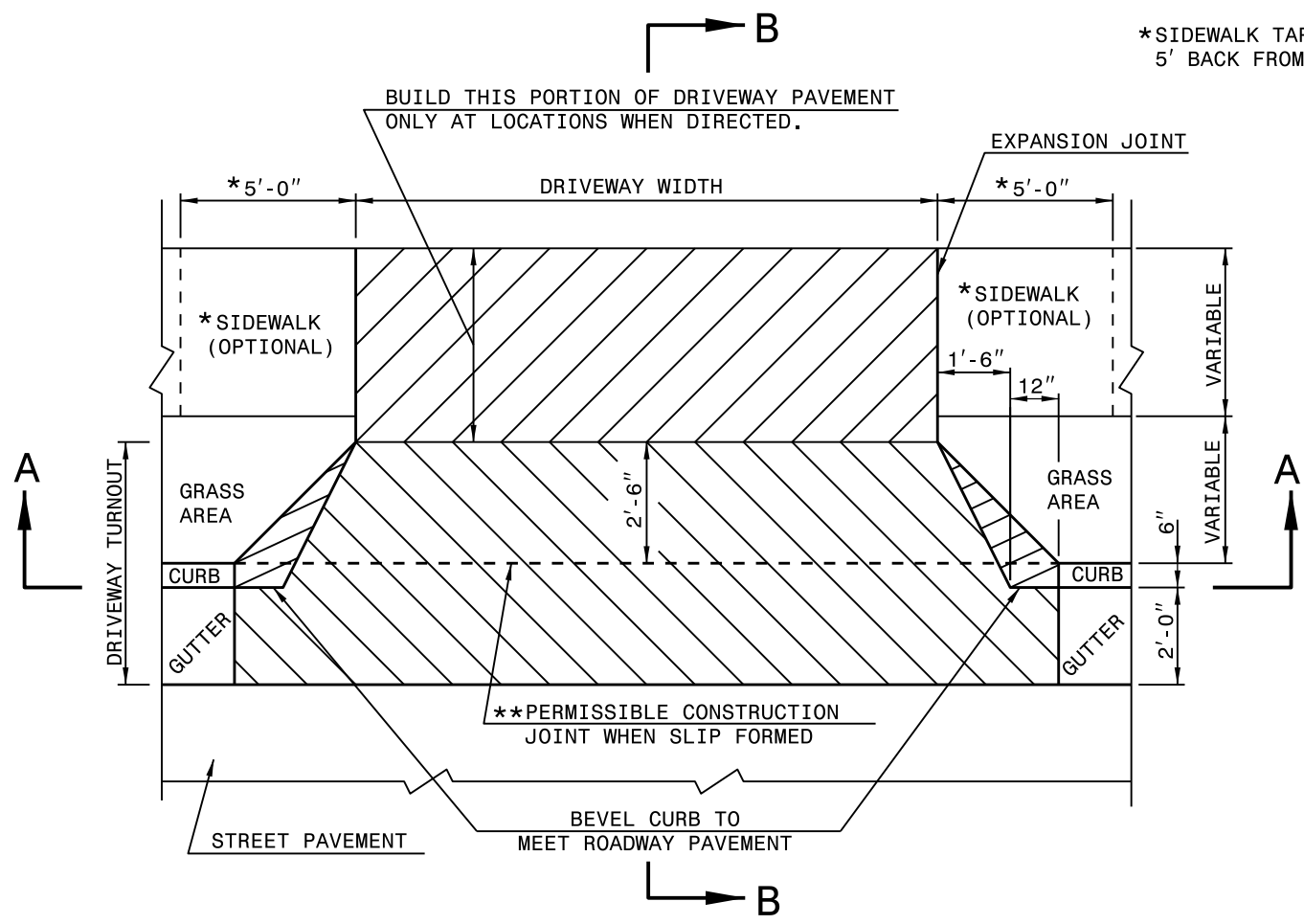

**METHOD OF TIE IN**

WHEN EXISTING DRIVEWAY PAVEMENT IS CONCRETE, SAW CUT 2" DEEP JOINT AT THE POINT OF TIE-IN. SAW JOINT PERPENDICULAR TO EDGE OF EXISTING DRIVEWAY PAVEMENT.

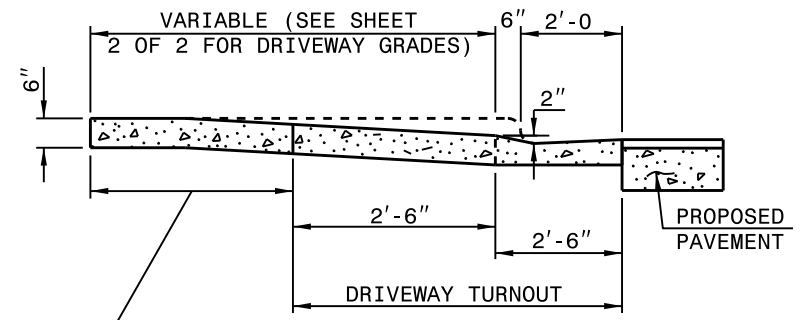

BUILD THIS PORTION OF DRIVEWAY PAVEMENT ONLY AT LOCATIONS WHEN DIRECTED.

**SECTION B-B**

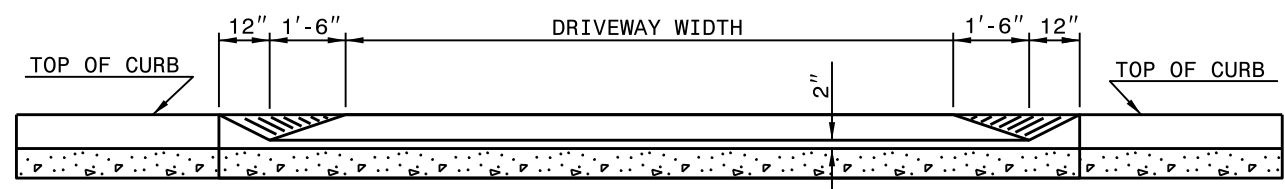

**SECTION A-A**

**GENERAL NOTES:**

\*\*NO CONSTRUCTION JOINT WILL BE PERMITTED IF FORMS ARE USED TO CAST DRIVEWAY. SLIP FORMING OF CURB AND GUTTER PERMITS THE USE OF CONSTRUCTION JOINT.

### DESIRABLE DRIVEWAY GRADES

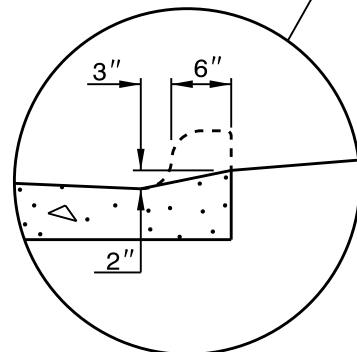
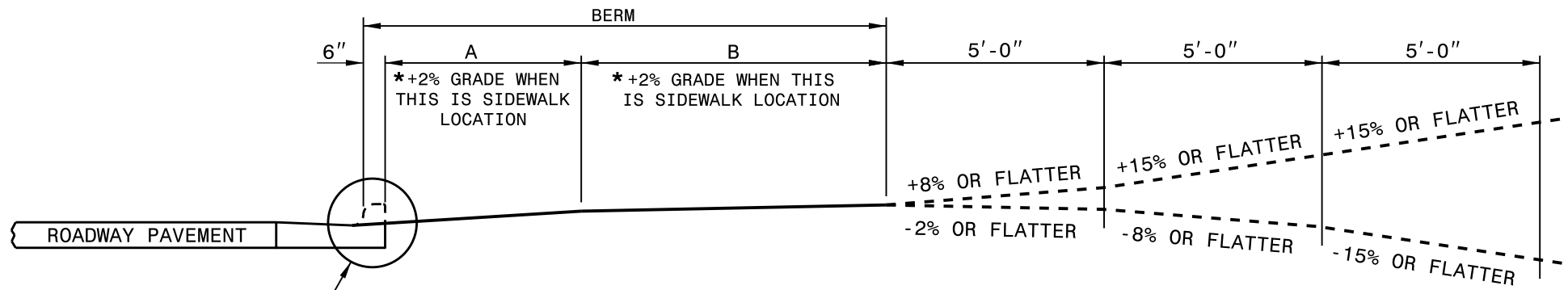

\*SIDEWALK LOCATION  
(DO NOT PLACE SIDEWALK ON  
BERMS LESS THAN 6' WIDE.)

DESIRABLE OR MAXIMUM DRIVEWAY GRADES				
BERM WIDTH	A		B	
	DIST.	GRADE	DIST.	GRADE
8' OR LESS	5'-0"	+2%*	2'-6"	+5%
8' OR LESS	2'-0"	+6%	5'-6"	+2%*
10'	4'-0"	+4%	5'-6"	+2%*
12' & OVER	4'-6"	+4%	7'-0"	+2%*

### MAXIMUM DRIVEWAY GRADES

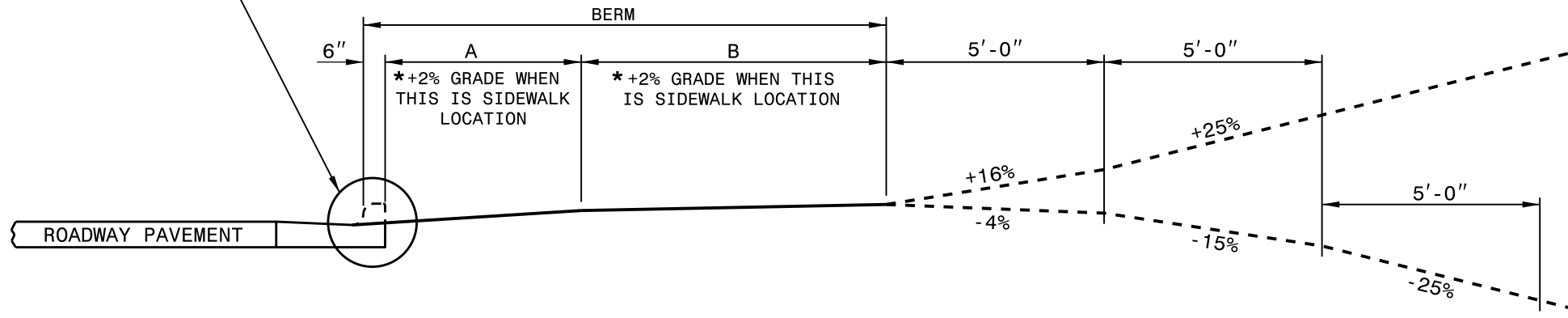

WIDTH OF PROPOSED OR EXISTING STREET

TERMINATING POINT FOR PROPOSED PAVEMENT

RADIUS AS SHOWN ON PLANS

RADIUS AS SHOWN ON PLANS

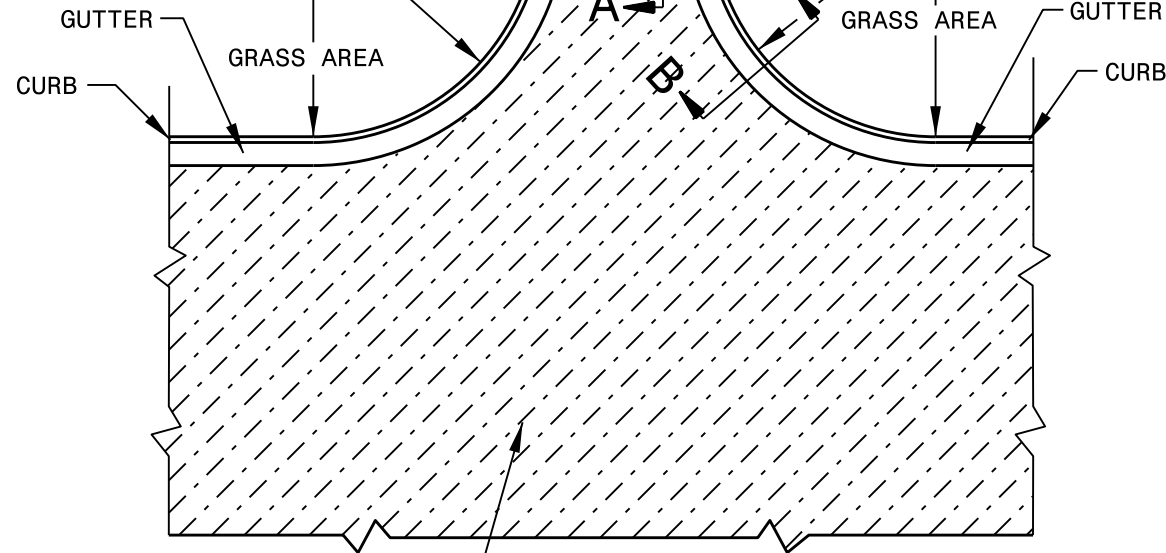

SURFACE THIS AREA AS SHOWN IN TYPICAL SECTION OF PLANS.

### PARTIAL PLAN OF PAVED STREET TURNOUT

USE ON PROPOSED AND EXISTING STREET INTERSECTIONS OR MAJOR TYPE COMMERCIAL ENTRANCES.

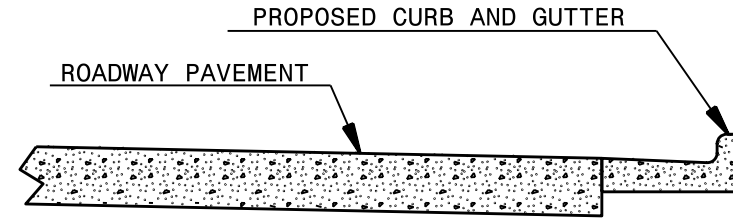

### SECTION B-B

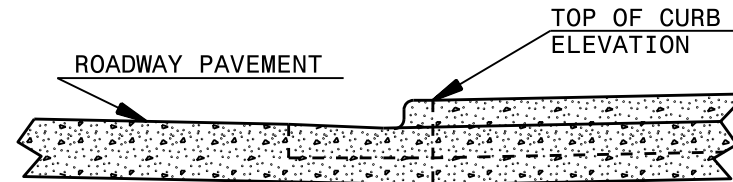

### SECTION A-A

STATE OF NORTH CAROLINA  
DEPT. OF TRANSPORTATION  
DIVISION OF HIGHWAYS  
RALEIGH, N.C.

1-24

ROADWAY STANDARD DRAWING FOR

## **STREET TURNOUT**

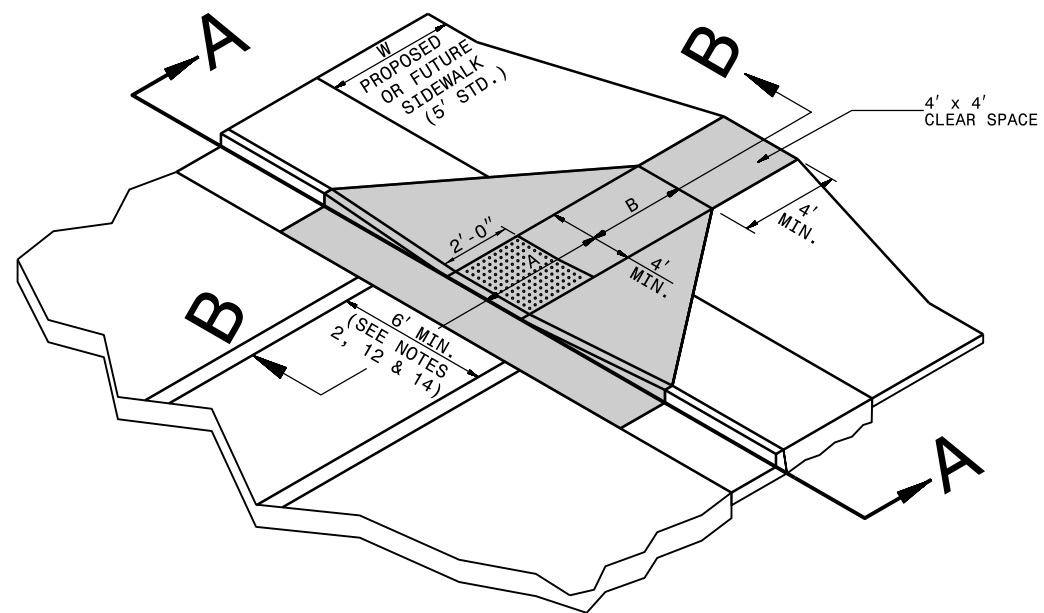

**ISOMETRIC VIEW**

PAY LIMITS FOR CURB RAMP

NOTES:  
DETECTABLE WARNING SURFACE SHALL COVER 2'-0" LENGTH AND FULL WIDTH OF THE RAMP FLOOR AS SHOWN ON THE DETAILS.  
DETECTABLE WARNING SURFACE SHALL CONTRAST VISIBLY WITH ADJOINING SURFACE, EITHER LIGHT-ON-DARK, OR DARK-ON-LIGHT SEQUENCE COVERING THE ENTIRE RAMP.

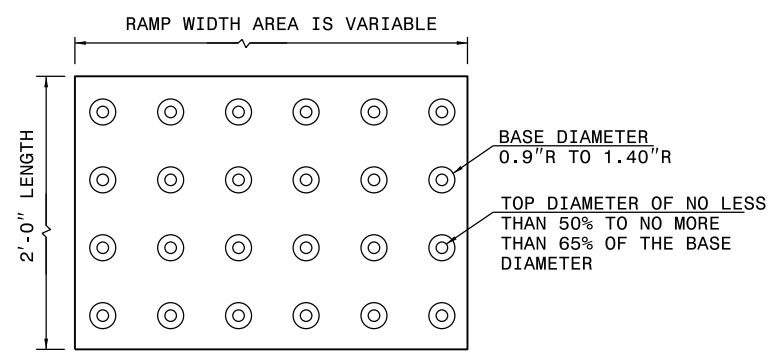

W	A	W+A+9"	X	B
5'	0.0'	5.8'	5.8'	5.0'*
6'	0.0'	6.8'	6.8'	6.0'**
7'	0.0'	7.8'	7.3'	6.5'**
8'	0.0'	8.8'	7.3'	6.5'**
5'	2.0'	7.8'	7.8'	5.0'
5'	2.5'	8.3'	8.1'	4.8'
5'	3.0'	8.8'	8.3'	4.4'
5'	3.5'	9.3'	8.4'	4.1'
5'	4.0'	9.8'	8.6'	3.8'
5'	4.5'	10.3'	8.7'	3.4'
5'	5.0'	10.8'	8.9'	3.1'

$B = X - (A + 9")$   
 B = DISTANCE FROM FRONT EDGE OF SIDEWALK TO BACK POINT OF 12:1 (8.33%) SLOPE.  
 \* BACK OF SIDEWALK DROP REQUIRED FOR ALL SIDEWALK SLOPES.  
 \*\* BACK OF SIDEWALK DROP REQUIRED FOR SIDEWALK SLOPES 0.04.

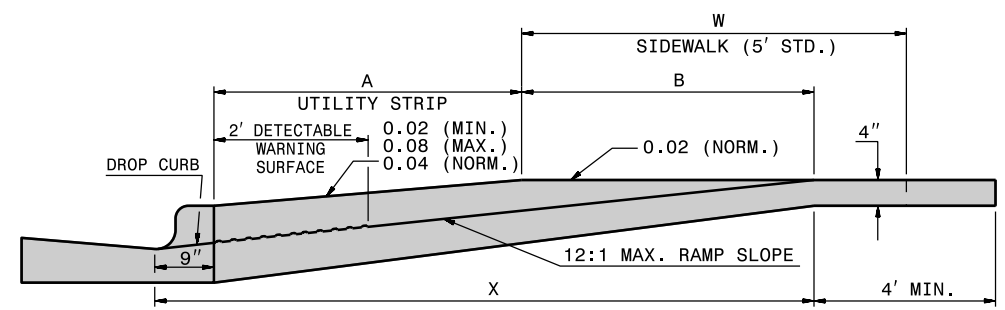

**SECTION B-B**

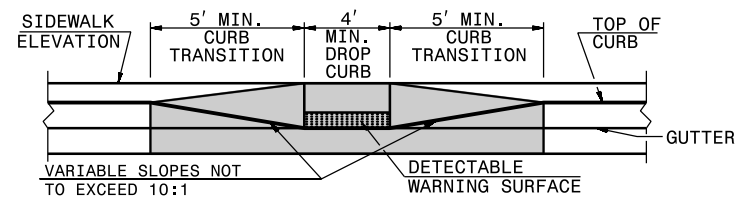

**SECTION A-A**

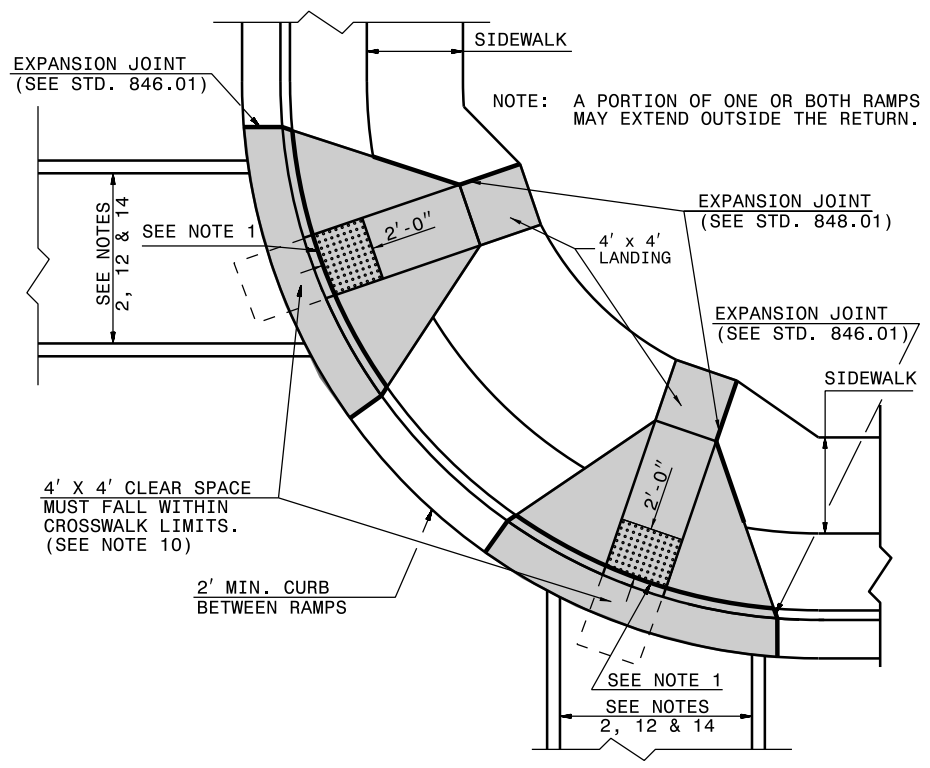

**PLAN VIEW**

DUAL RAMPS  
ANY RADII  
(4' MIN. FLOOR WIDTH)

**DETECTABLE WARNING SURFACE**

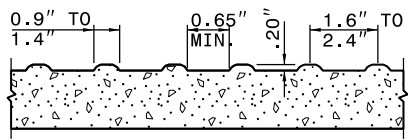

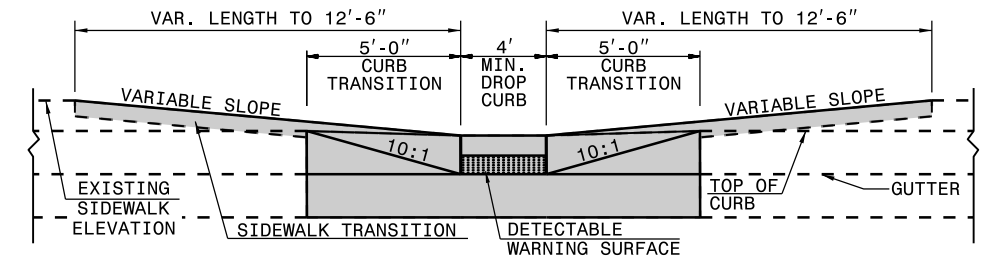
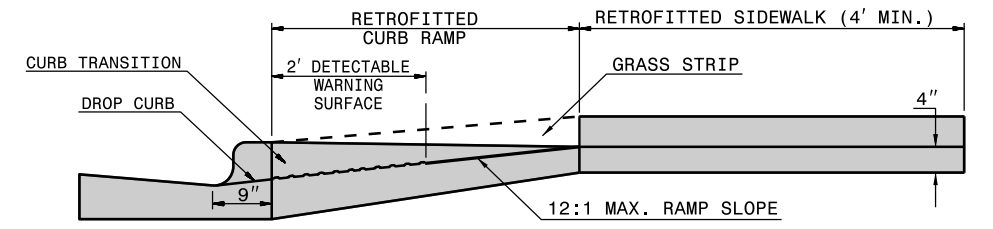
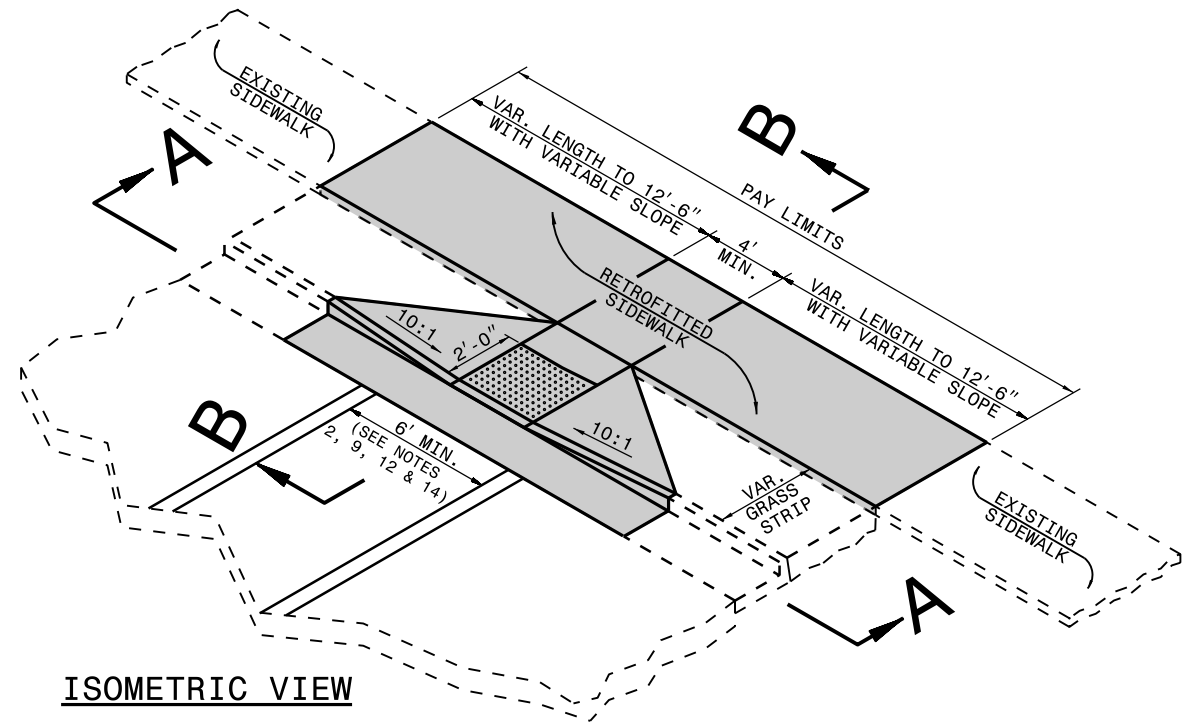

**NOTES:**  
DETECTABLE WARNING SURFACE SHALL COVER 2'-0" LENGTH AND FULL WIDTH OF THE RAMP FLOOR AS SHOWN ON THE DETAILS.  
DETECTABLE WARNING SURFACE SHALL CONTRAST VISIBLY WITH ADJOINING SURFACE, EITHER LIGHT-ON-DARK, OR DARK-ON-LIGHT SEQUENCE COVERING THE ENTIRE RAMP.

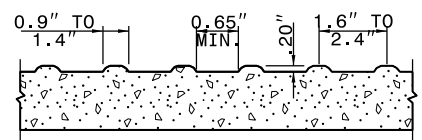
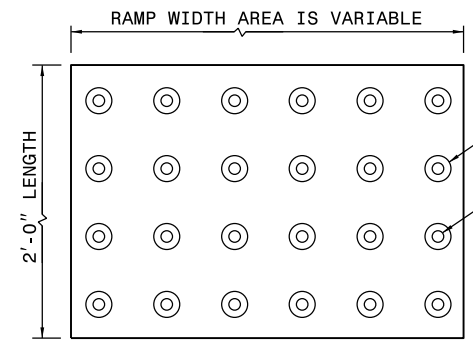

**DETECTABLE WARNING SURFACE**

PAY LIMITS OF CURB RAMP

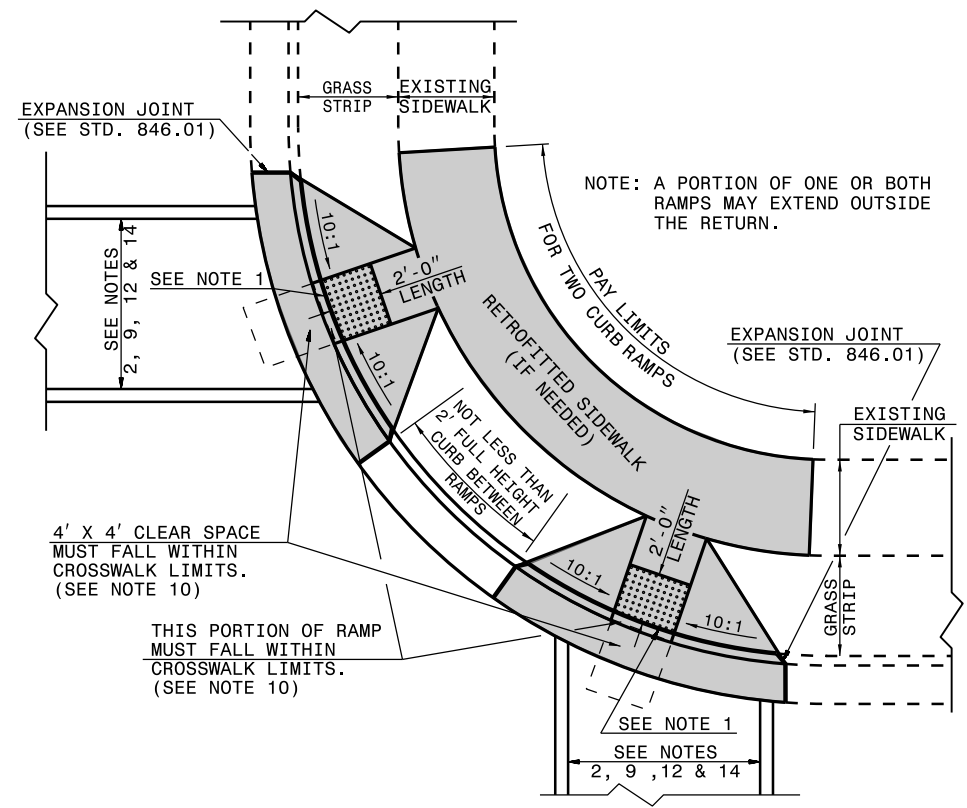

**PLAN VIEW**

DUAL RAMPS  
ANY RADII  
(40" MIN. FLOOR WIDTH)

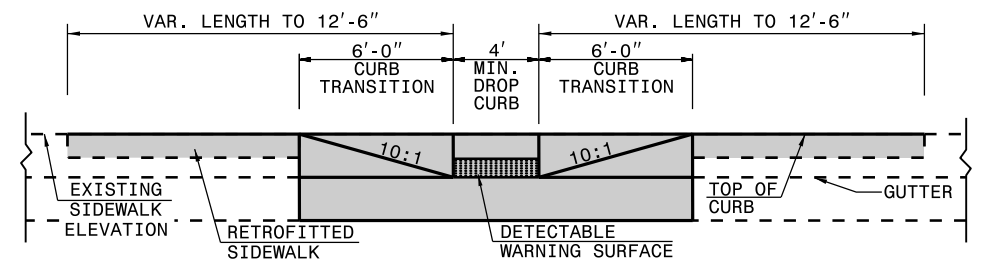
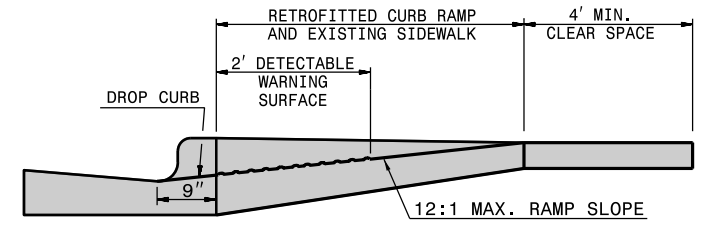
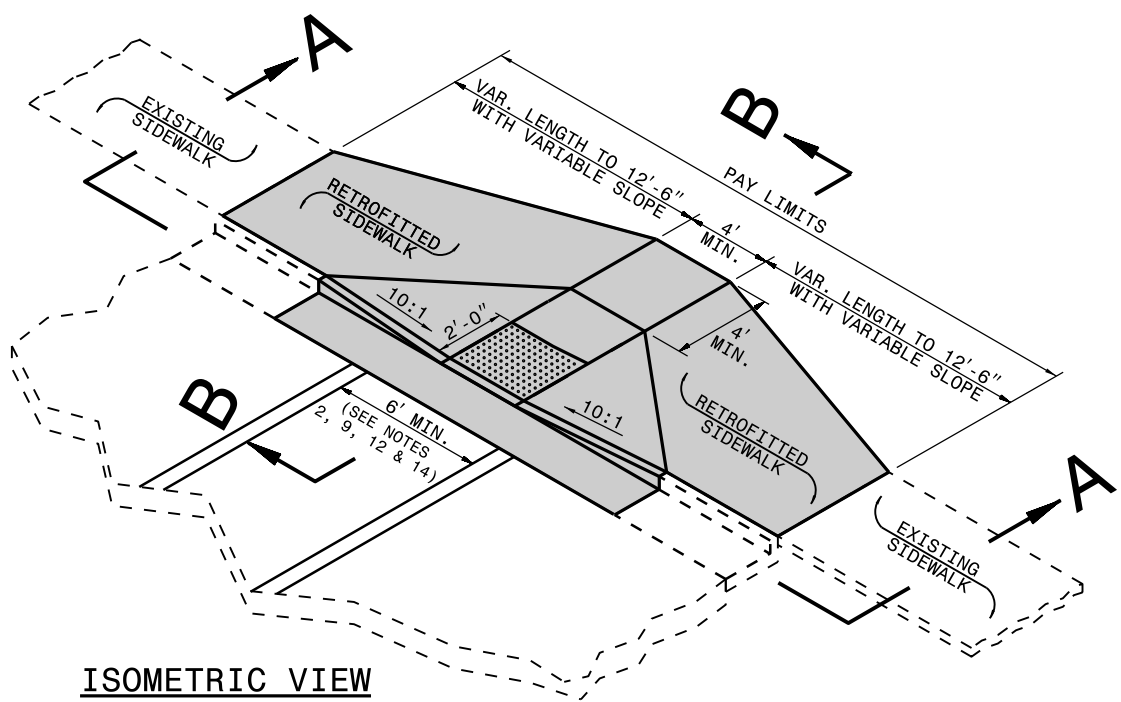

NOTES:  
DETECTABLE WARNING SURFACE SHALL COVER 2'-0" LENGTH AND FULL WIDTH OF THE RAMP FLOOR AS SHOWN ON THE DETAILS.  
DETECTABLE WARNING SURFACE SHALL CONTRAST VISIBLY WITH ADJOINING SURFACE, EITHER LIGHT-ON-DARK, OR DARK-ON-LIGHT SEQUENCE COVERING THE ENTIRE RAMP.

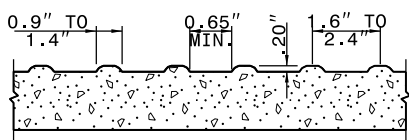
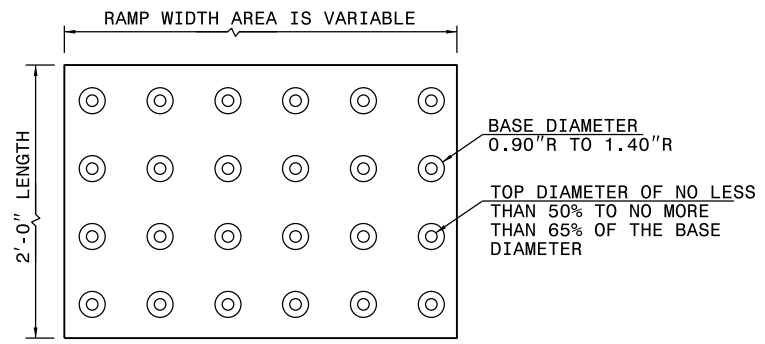

**DETECTABLE WARNING SURFACE**

PAY LIMITS OF CURB RAMP

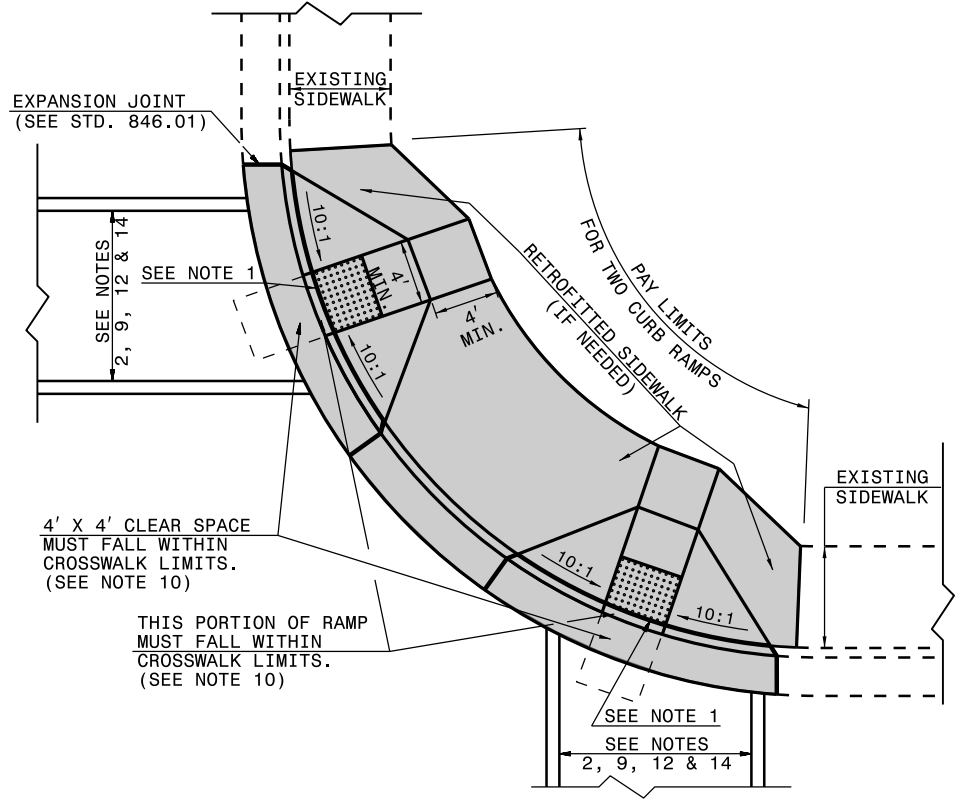

**PLAN VIEW**

DUAL RAMPS  
ANY RADII  
(40" MIN. FLOOR WIDTH)

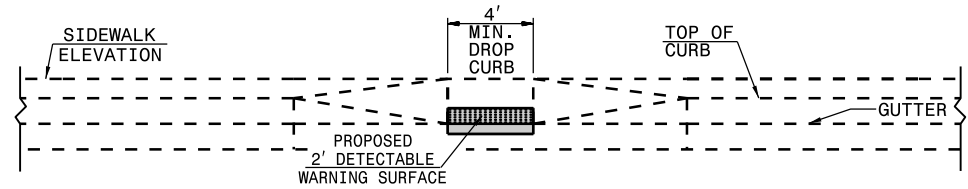
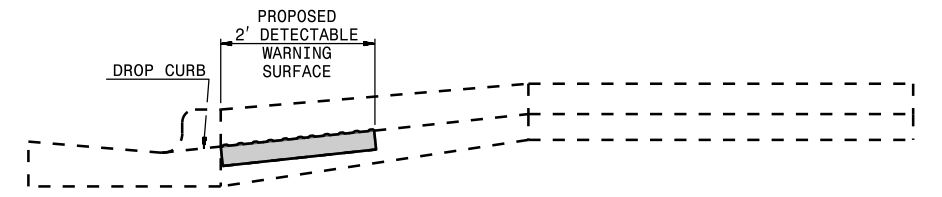
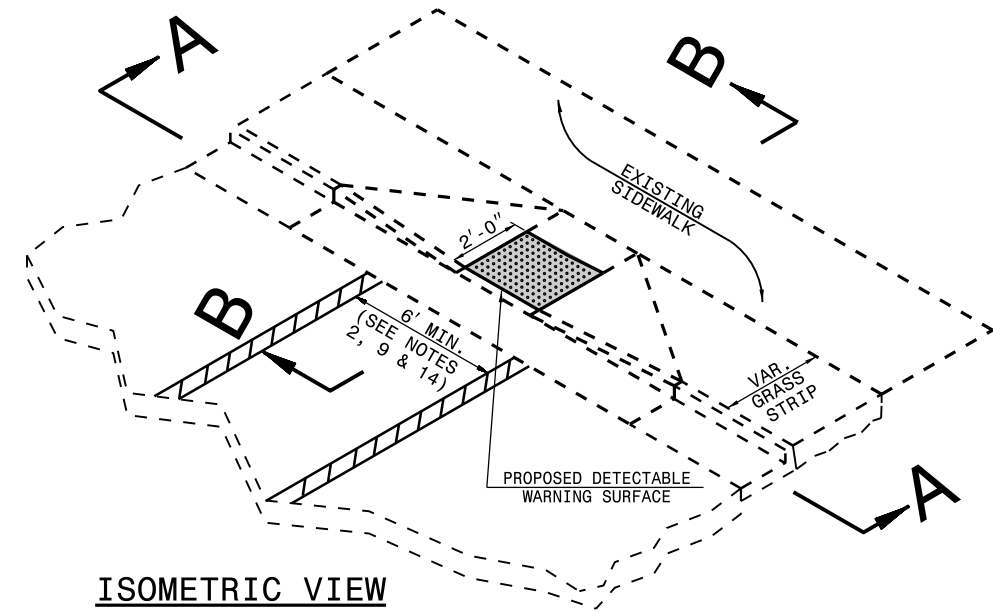

NOTES:  
 DETECTABLE WARNING SURFACE SHALL COVER 2'-0" LENGTH AND FULL WIDTH OF THE RAMP FLOOR AS SHOWN ON THE DETAILS.  
 DETECTABLE WARNING SURFACE SHALL CONTRAST VISIBLY WITH ADJOINING SURFACE, EITHER LIGHT-ON-DARK, OR DARK-ON-LIGHT SEQUENCE COVERING THE ENTIRE RAMP.

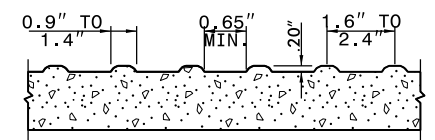
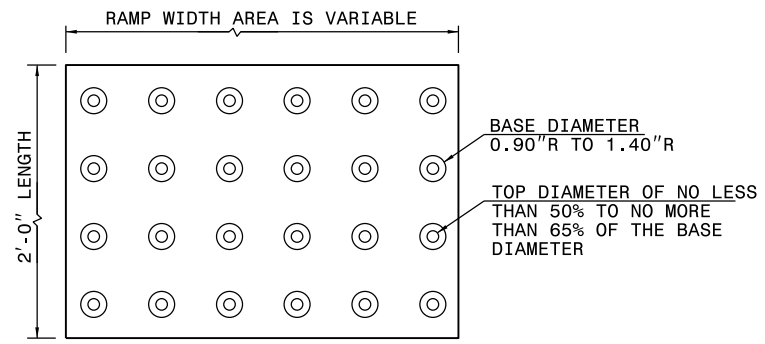

**DETECTABLE WARNING SURFACE**

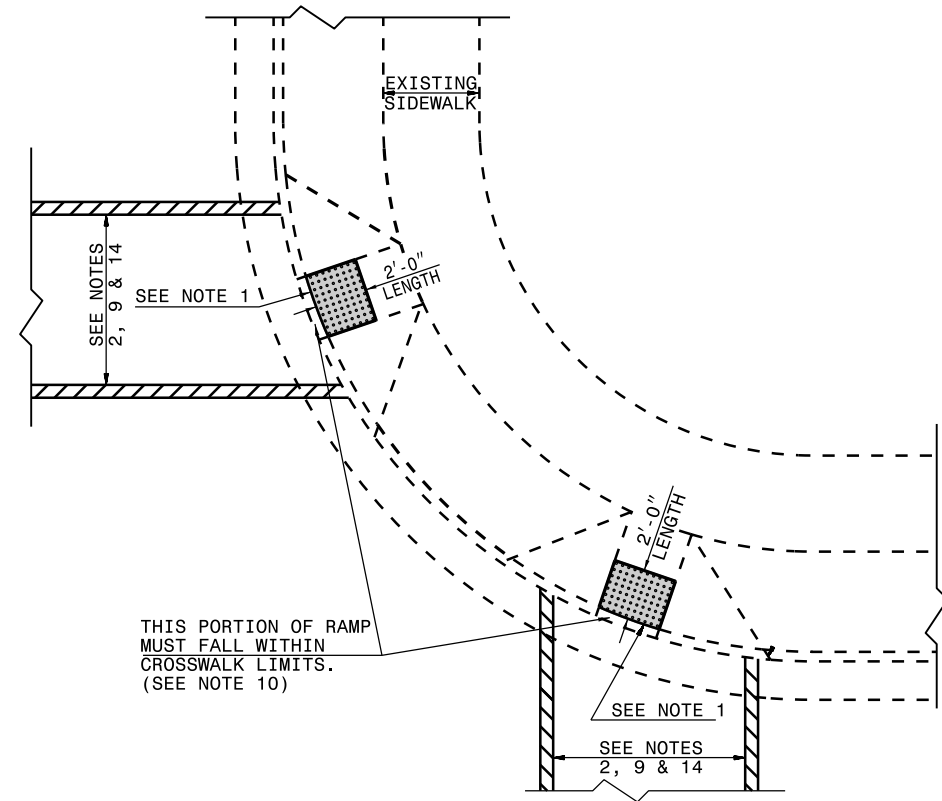

PAY LIMITS OF RETROFIT CURB RAMP

**PLAN VIEW**  
 DUAL RAMPS  
 ANY RADII  
 (40" MIN. FLOOR WIDTH)



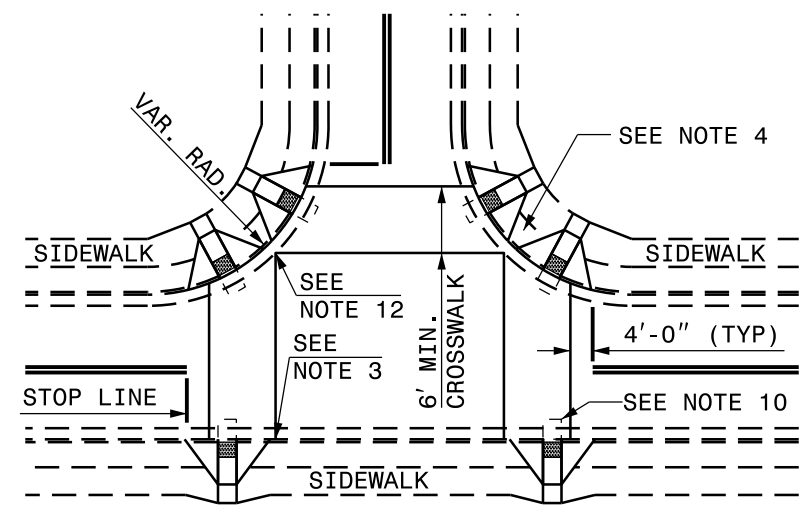

DETAIL SHOWING TYPICAL LOCATION OF CURB RAMPS,  
PEDESTRIAN CROSSWALKS AND STOP LINES FOR TEE INTERSECTIONS

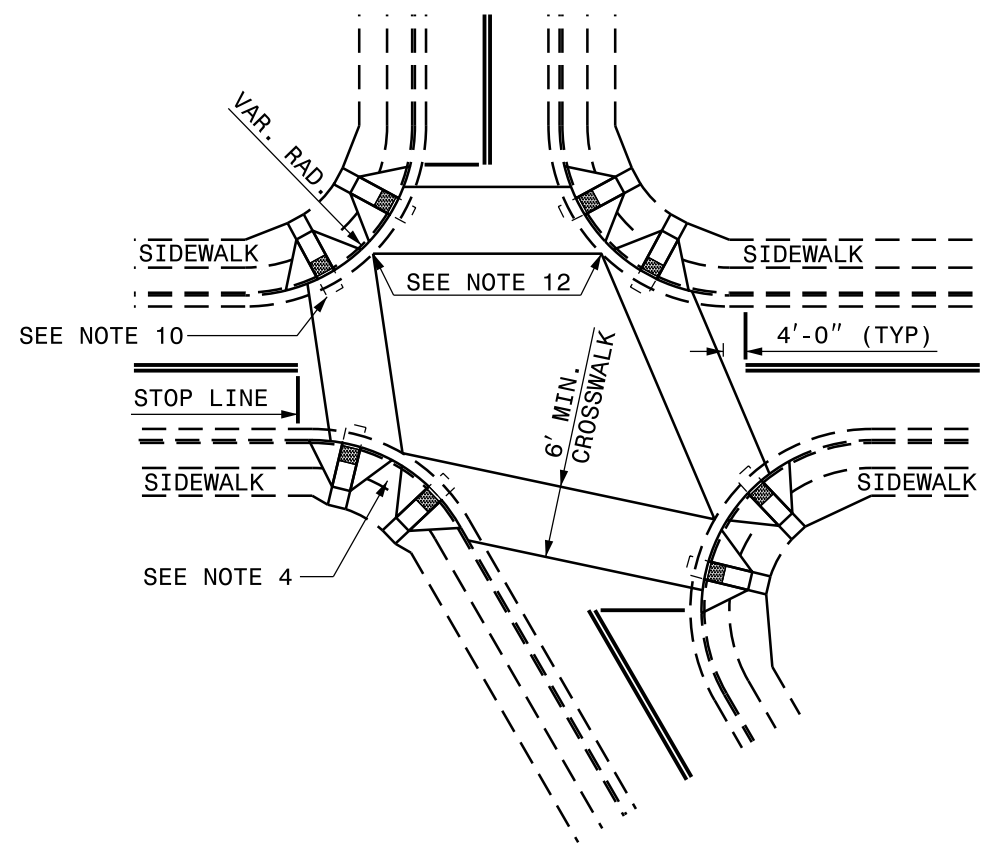

DETAIL SHOWING TYPICAL LOCATION OF CURB  
RAMPS, PEDESTRIAN CROSSWALKS AND STOP LINES

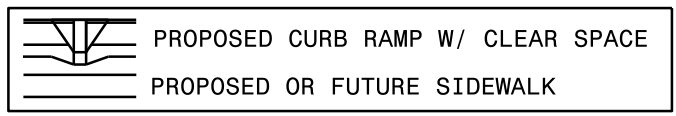
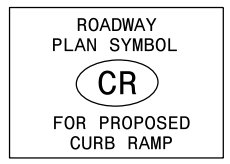

ALLOWABLE LOCATIONS  
-----  
DUAL RAMP RADII.....ANY

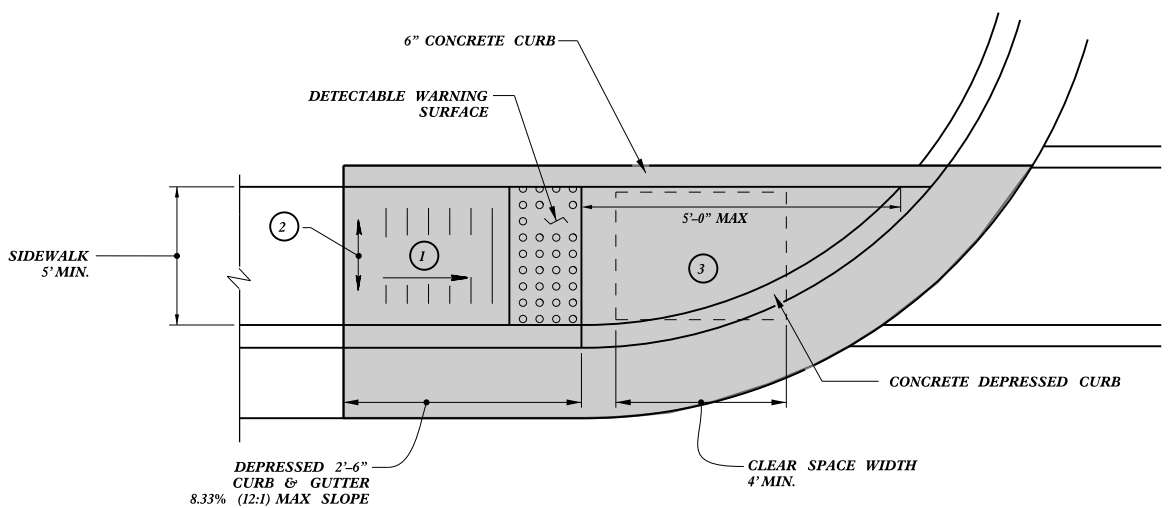

**TYPE 1**

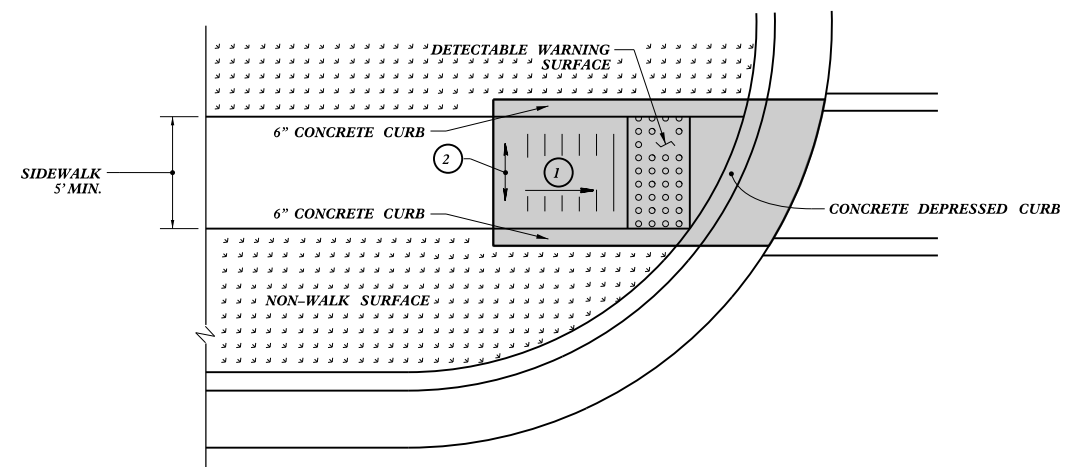

**TYPE 1 MODIFIED**

- 1 8.33% (12:1) MAX RAMP SLOPE
- 2 CROSS SLOPE: 2.00%
- 3 MAXIMUM CROSS SLOPE AND LONGITUDINAL SLOPE OF 2.00%.

NOTES:  
DETECTABLE WARNING SURFACE SHALL COVER 2'-0" LENGTH AND FULL WIDTH OF THE RAMP FLOOR AS SHOWN ON THE DETAILS.  
DETECTABLE WARNING SURFACE SHALL CONTRAST VISIBLY WITH ADJOINING SURFACE, EITHER LIGHT-ON-DARK, OR DARK-ON-LIGHT SEQUENCE COVERING THE ENTIRE RAMP.

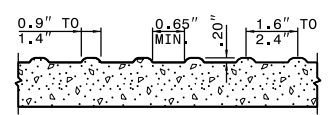
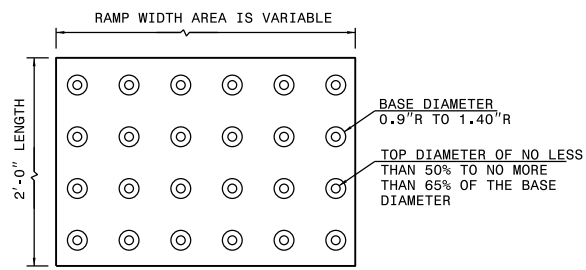

**DETECTABLE WARNING SURFACE**

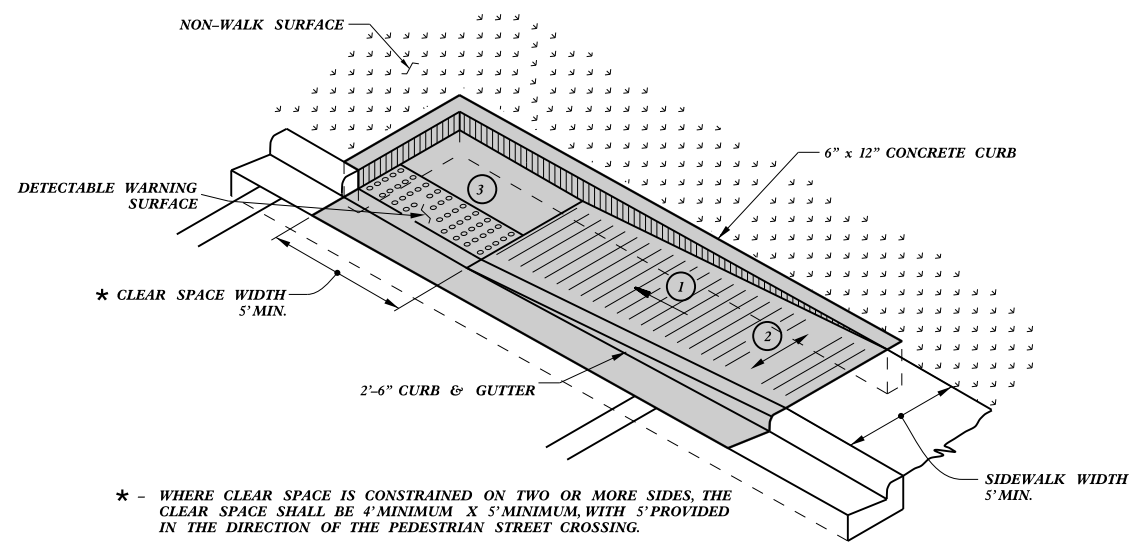

**TYPE 1A**

PAY LIMITS FOR 1 CURB RAMP

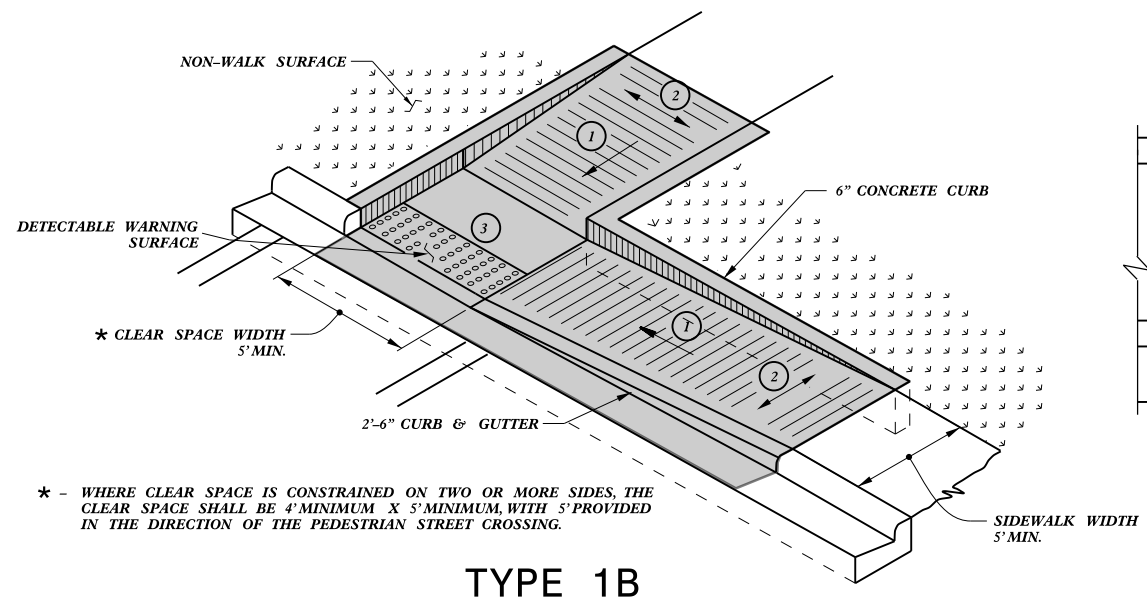

**TYPE 1B**

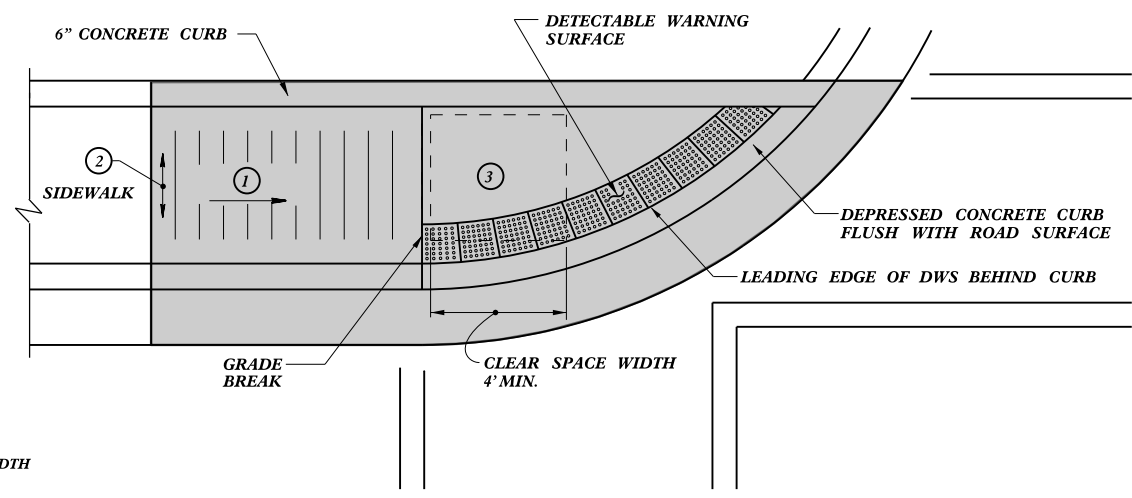

**TYPE 1C**

- ① 8.33% (12:1) MAX RAMP SLOPE
- ② CROSS SLOPE: 2.00%
- ③ MAXIMUM CROSS SLOPE AND LONGITUDINAL SLOPE OF 2.00%

NOTES:  
DETECTABLE WARNING SURFACE SHALL COVER 2'-0" LENGTH AND FULL WIDTH OF THE RAMP FLOOR AS SHOWN ON THE DETAILS.  
DETECTABLE WARNING SURFACE SHALL CONTRAST VISIBLY WITH ADJOINING SURFACE, EITHER LIGHT-ON-DARK, OR DARK-ON-LIGHT SEQUENCE COVERING THE ENTIRE RAMP.

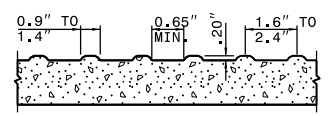
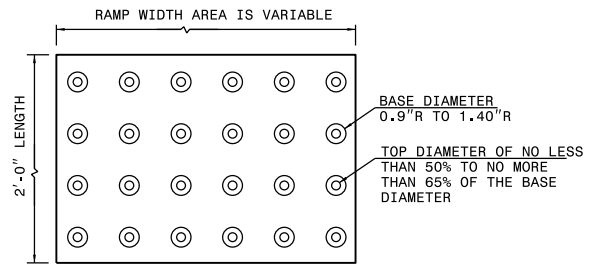

**DETECTABLE WARNING SURFACE**

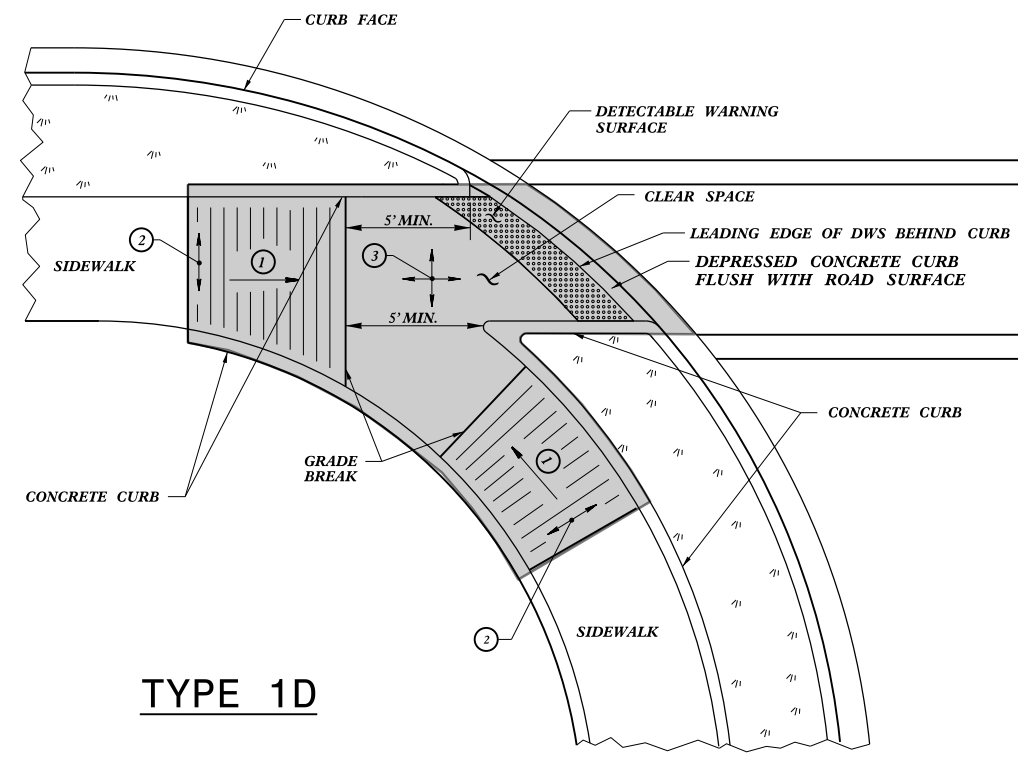

**TYPE 1D**

PAY LIMITS FOR 1 CURB RAMP

**CURB RAMP**  
PARALLEL RAMP

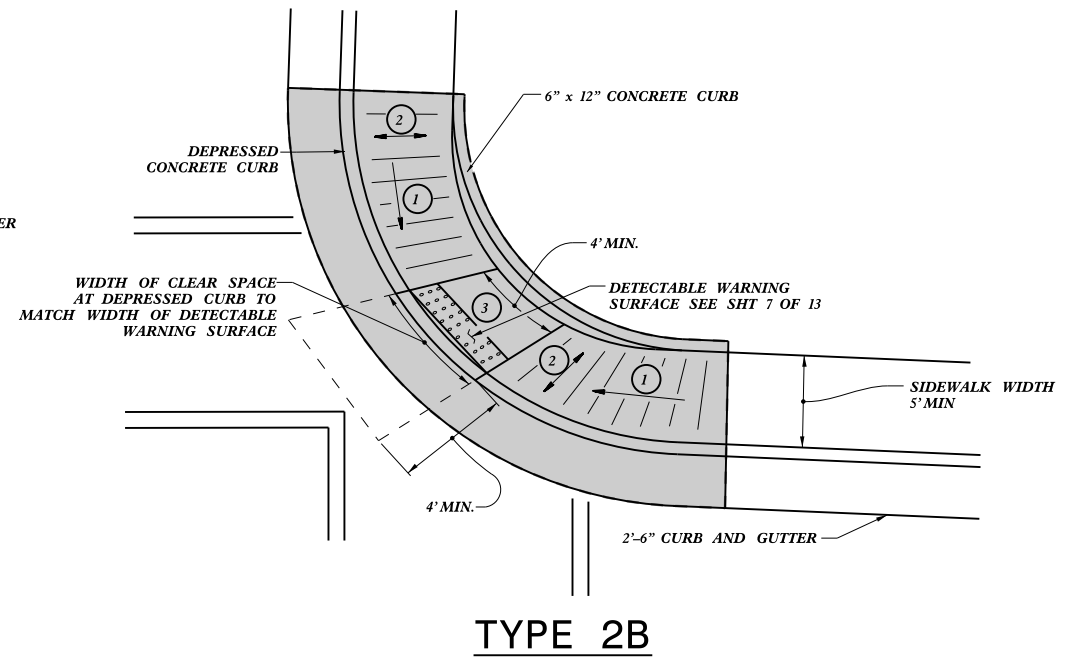
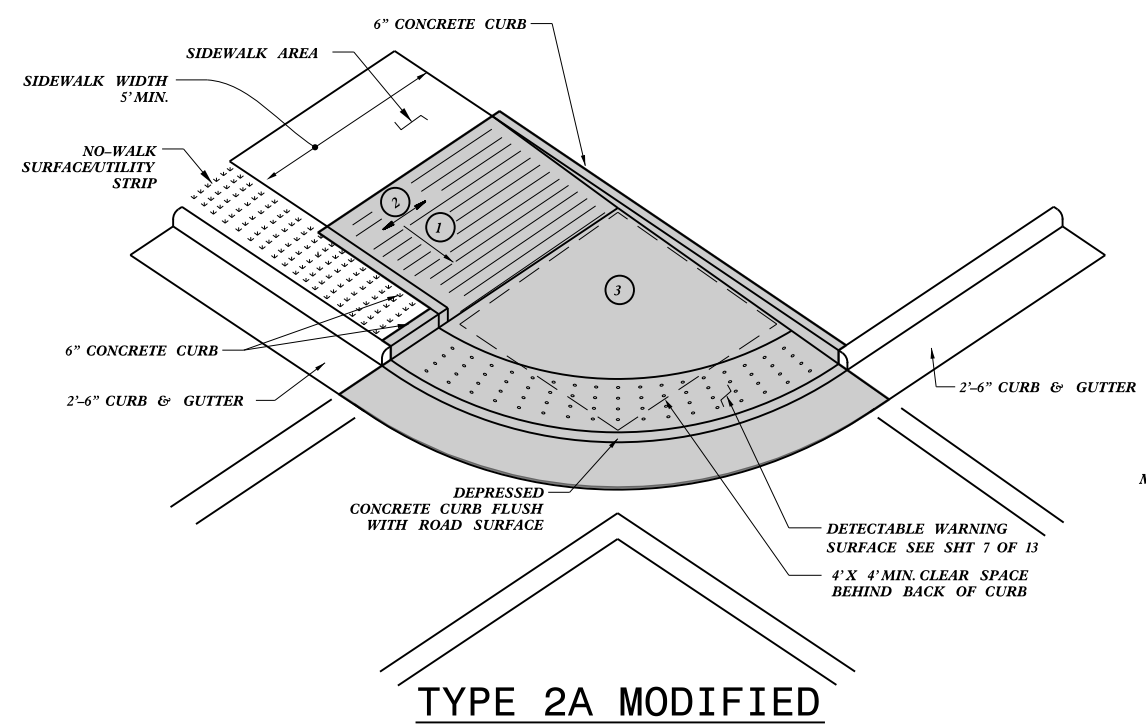
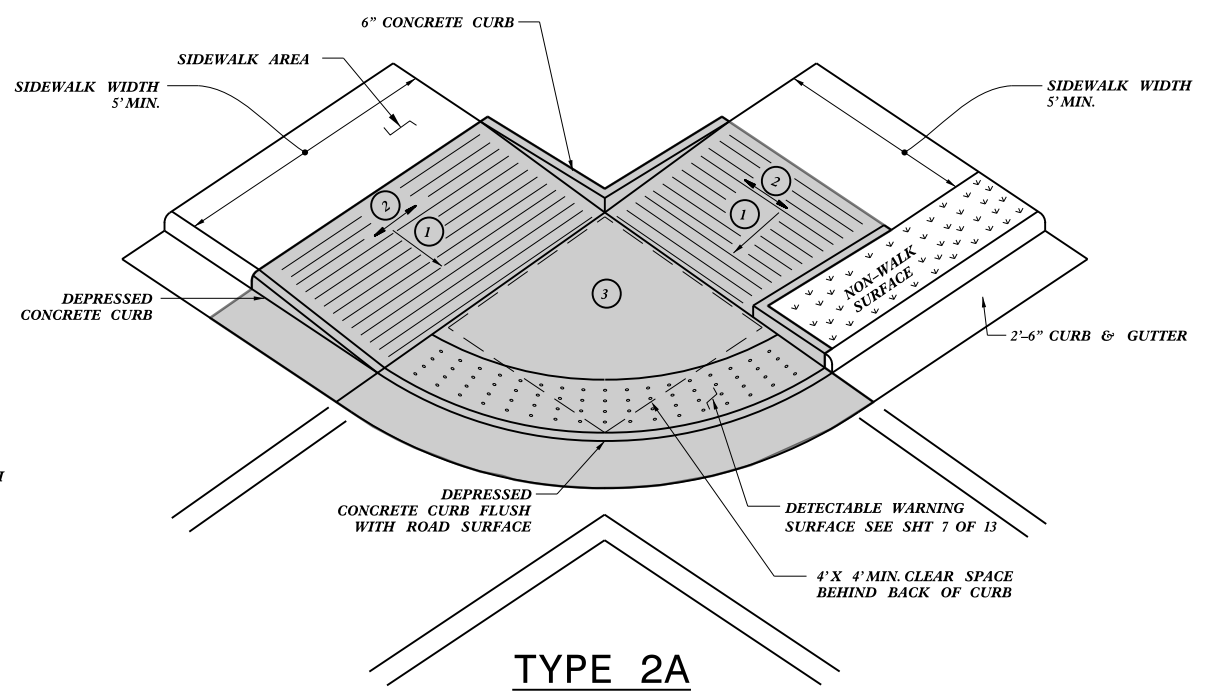
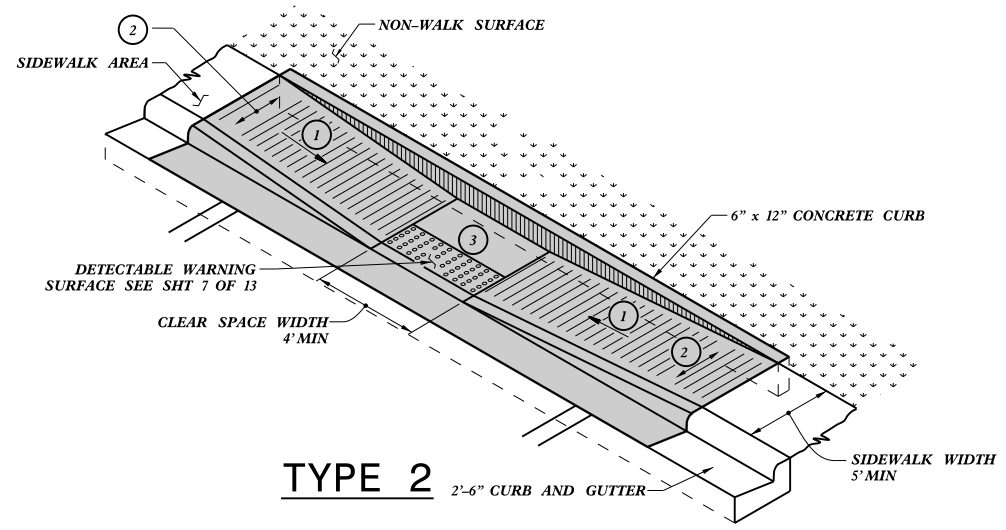

- ① 8.33% (12:1) MAX RAMP SLOPE
- ② CROSS SLOPE: 2.00%
- ③ MAXIMUM CROSS SLOPE AND LONGITUDINAL SLOPE OF 2.00%.

PAY LIMITS FOR 1 CURB RAMP

\* - WHERE CLEAR SPACE IS CONSTRAINED ON TWO OR MORE SIDES, THE CLEAR SPACE SHALL BE 4' MINIMUM X 5' MINIMUM, WITH 5' PROVIDED IN THE DIRECTION OF THE PEDESTRIAN STREET CROSSING.

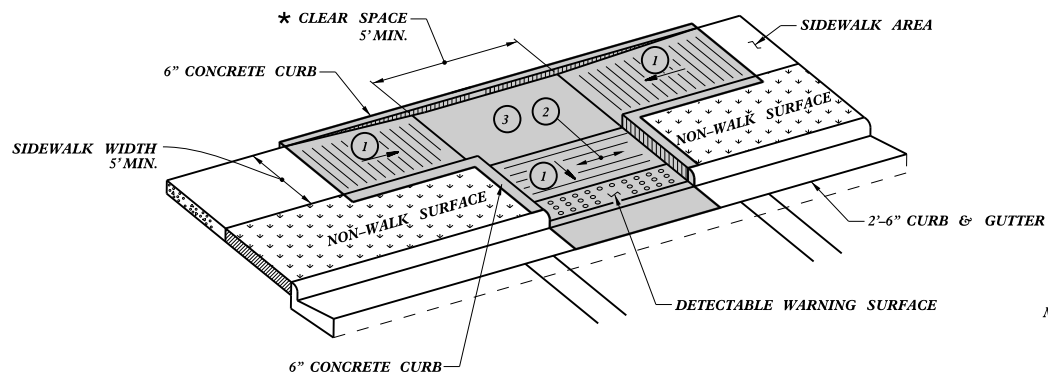

**TYPE 3**

**NOTES:**

DETECTABLE WARNING SURFACE SHALL COVER 2'-0" LENGTH AND FULL WIDTH OF THE RAMP FLOOR AS SHOWN ON THE DETAILS.

DETECTABLE WARNING SURFACE SHALL CONTRAST VISIBLY WITH ADJOINING SURFACE, EITHER LIGHT-ON-DARK, OR DARK-ON-LIGHT SEQUENCE COVERING THE ENTIRE RAMP.

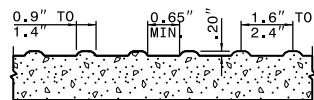
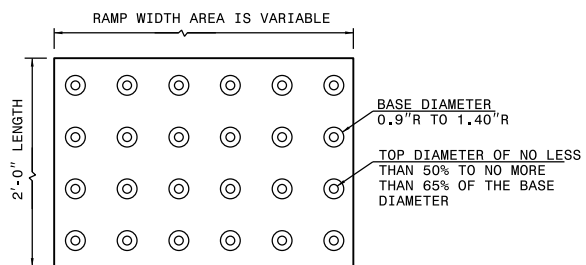

**DETECTABLE WARNING SURFACE**

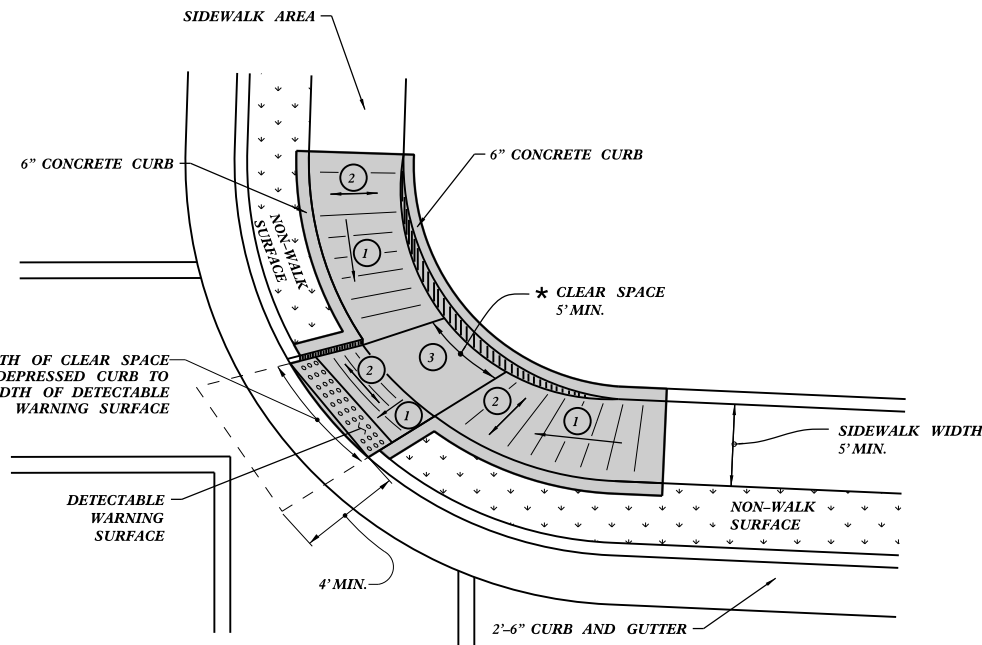

**TYPE 3 MODIFIED  
INSTALLATION IN A RADIUS**

- 1 8.33% (12:1) MAX RAMP SLOPE
- 2 CROSS SLOPE: 2.00%
- 3 MAXIMUM CROSS SLOPE AND LONGITUDINAL SLOPE OF 2.00%.

 PAY LIMITS FOR 1 CURB RAMP

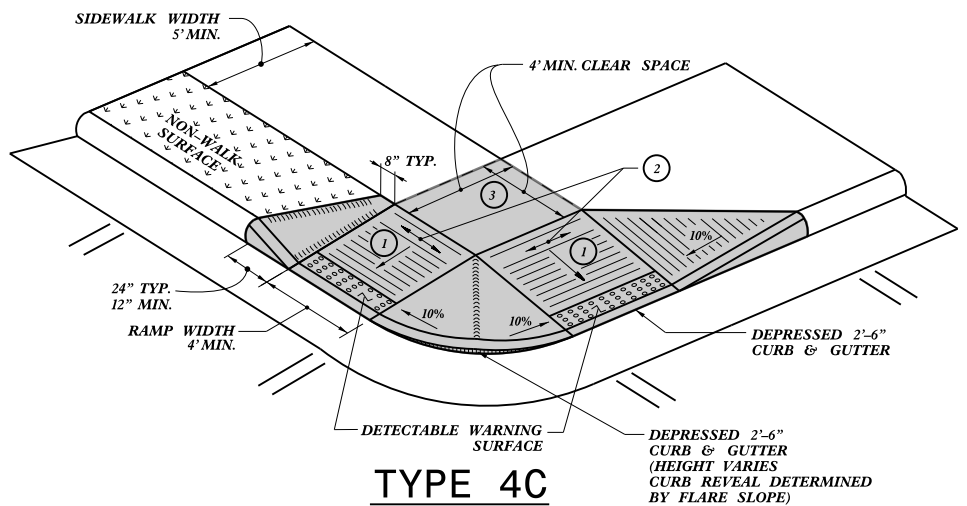
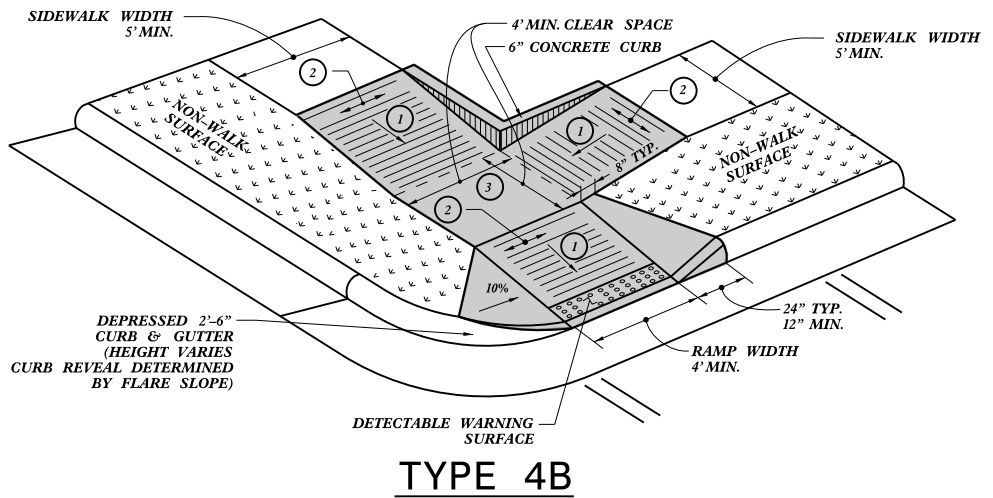
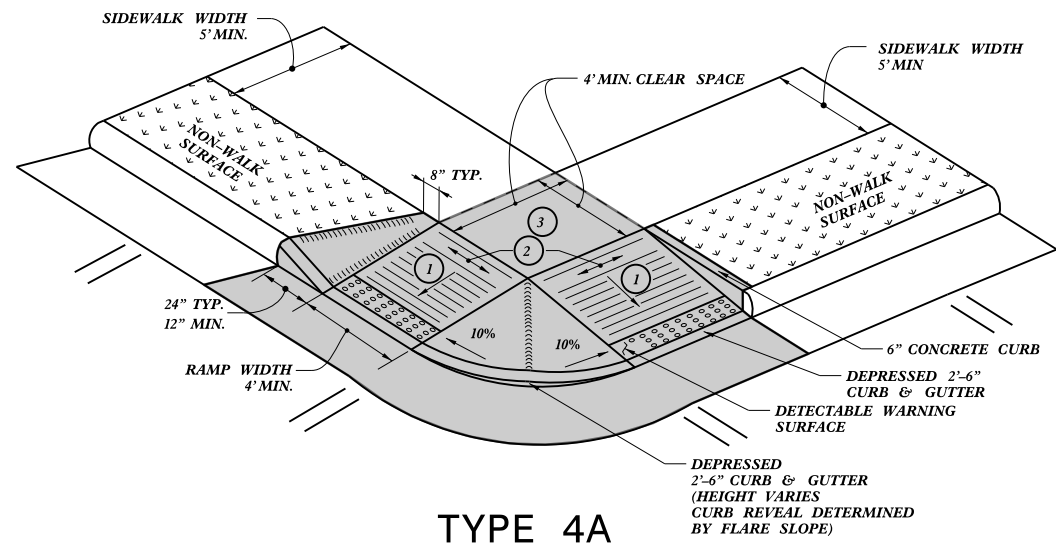
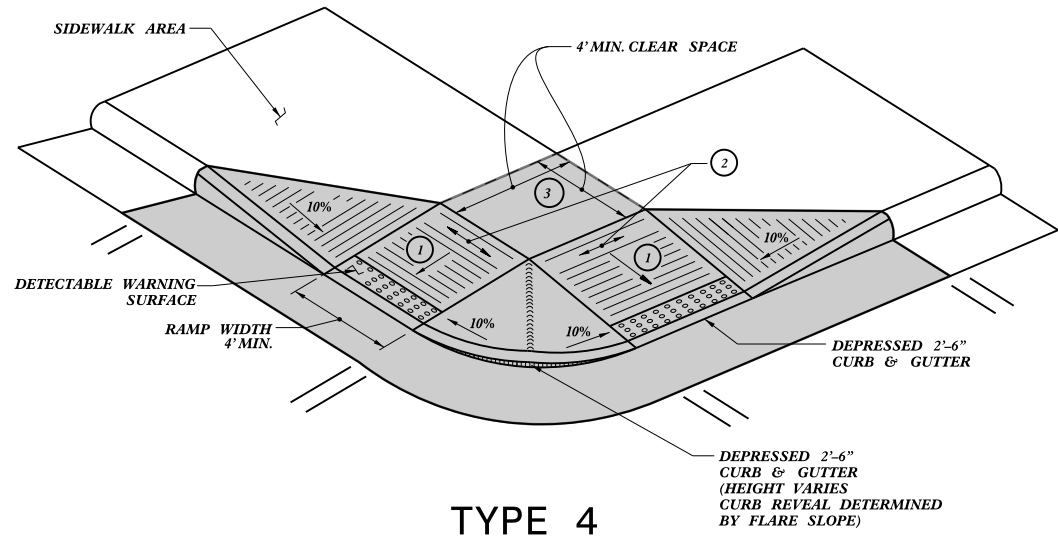

NOTES:  
DETECTABLE WARNING SURFACE SHALL COVER 2'-0" LENGTH AND FULL WIDTH OF THE RAMP FLOOR AS SHOWN ON THE DETAILS.  
DETECTABLE WARNING SURFACE SHALL CONTRAST VISIBLY WITH ADJOINING SURFACE, EITHER LIGHT-ON-DARK, OR DARK-ON-LIGHT SEQUENCE COVERING THE ENTIRE RAMP.

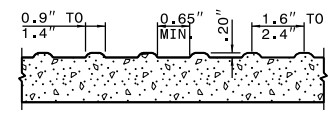
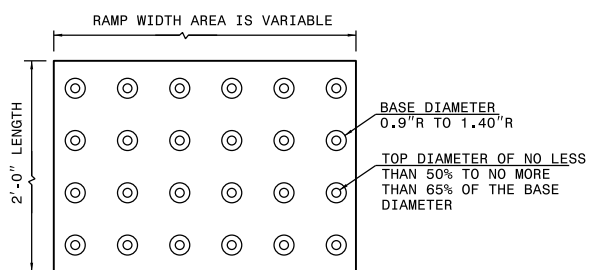

- ① 8.33% (12:1) MAX RAMP SLOPE
- ② CROSS SLOPE: 2.00%
- ③ MAXIMUM CROSS SLOPE AND LONGITUDINAL SLOPE OF 2.00%.

PAY LIMITS FOR 1 OR 2 CURB RAMPS (CALCULATE BASED ON NUMBER OF SETS OF DETECTABLE WARNING SURFACES)

**DETECTABLE WARNING SURFACE**

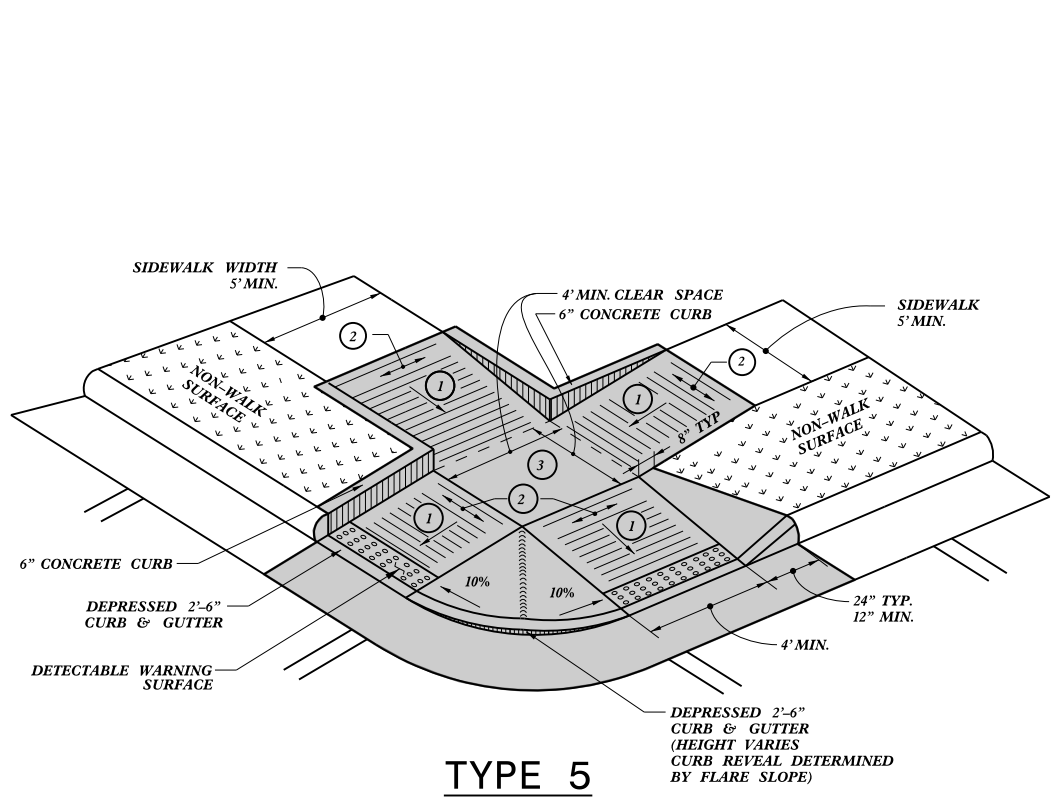

**TYPE 5**

NOTES:  
DETECTABLE WARNING SURFACE SHALL COVER 2'-0" LENGTH AND FULL WIDTH OF THE RAMP FLOOR AS SHOWN ON THE DETAILS.  
DETECTABLE WARNING SURFACE SHALL CONTRAST VISIBLY WITH ADJOINING SURFACE, EITHER LIGHT-ON-DARK, OR DARK-ON-LIGHT SEQUENCE COVERING THE ENTIRE RAMP.

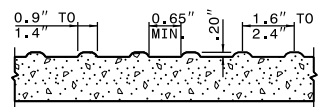
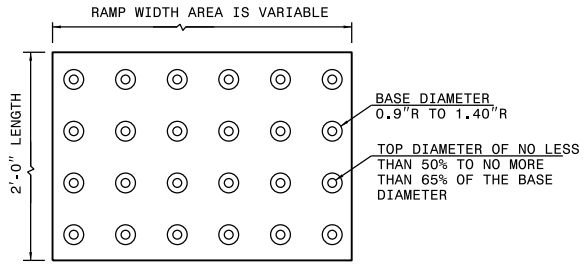

**DETECTABLE WARNING SURFACE**

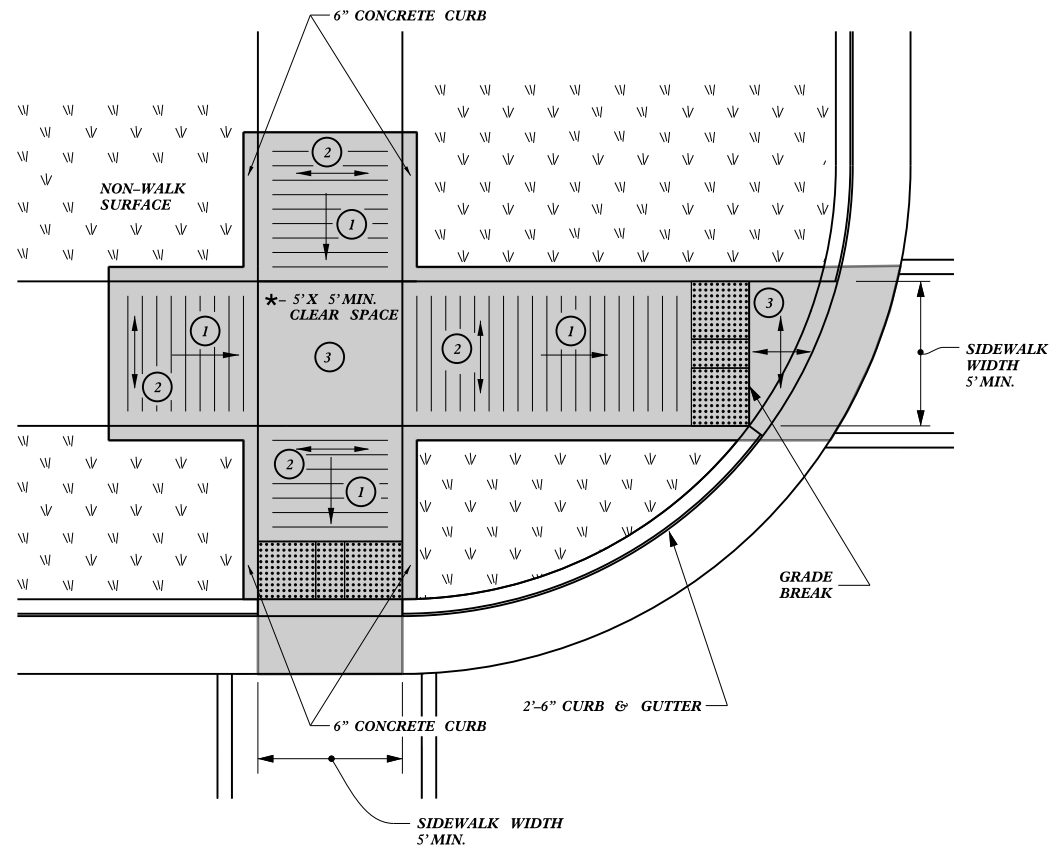

**TYPE 5A**

\* - WHERE CLEAR SPACE IS CONSTRAINED ON TWO OR MORE SIDES, THE CLEAR SPACE SHALL BE 4' MINIMUM X 5' MINIMUM, WITH 5' PROVIDED IN THE DIRECTION OF THE PEDESTRIAN STREET CROSSING.

- ① 8.33% (12:1) MAX RAMP SLOPE
- ② CROSS SLOPE: 2.00%
- ③ MAXIMUM CROSS SLOPE AND LONGITUDINAL SLOPE OF 2.00%

■ PAY LIMITS FOR 1 OR 2 CURB RAMPS (CALCULATE BASED ON NUMBER OF SETS OF DETECTABLE WARNING SURFACES)

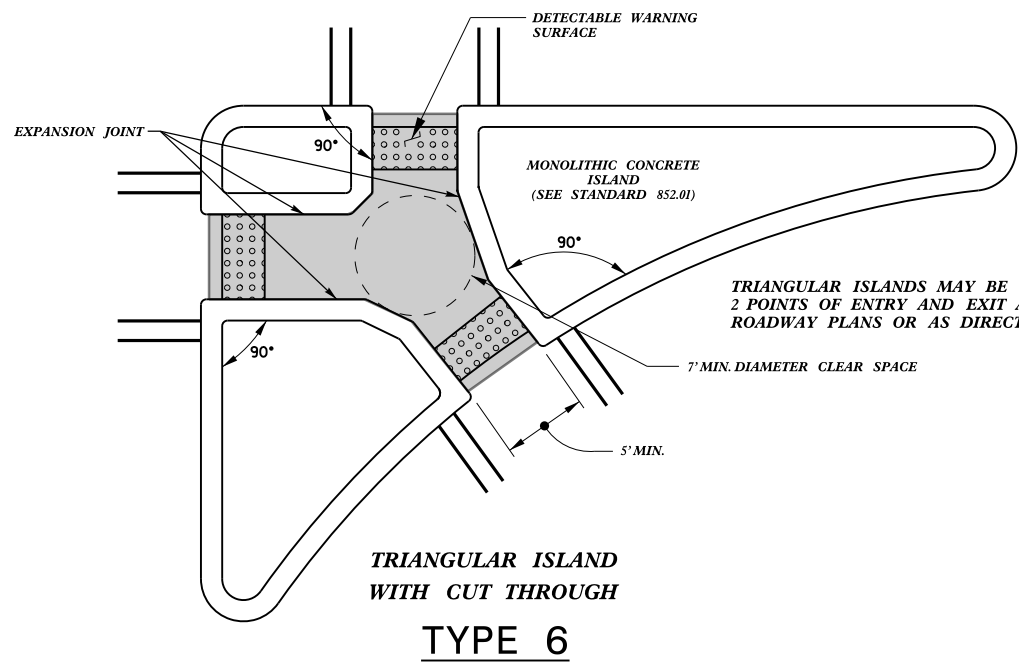

**TRIANGULAR ISLAND  
WITH CUT THROUGH  
TYPE 6**

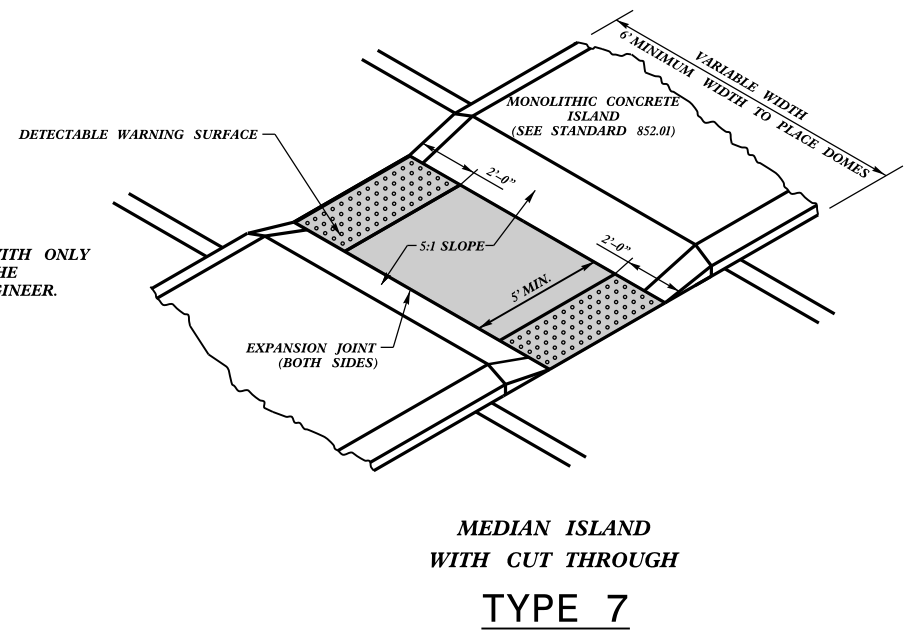

**MEDIAN ISLAND  
WITH CUT THROUGH  
TYPE 7**

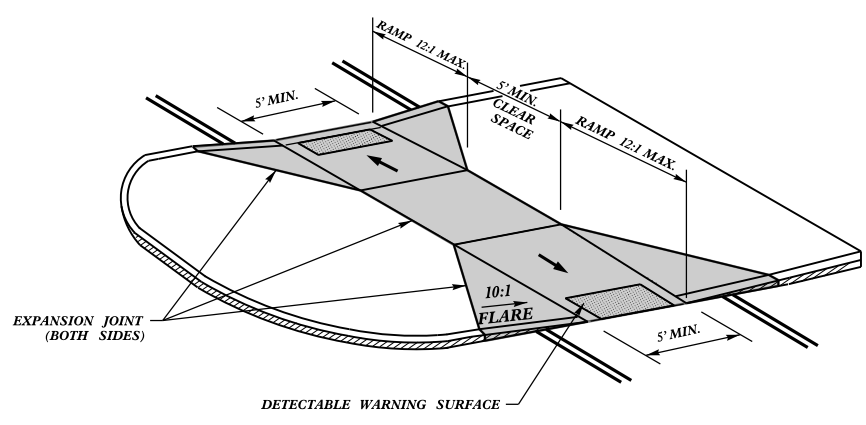

**MEDIAN ISLAND  
CURB RAMPS  
TYPE 8**

 PAY LIMITS FOR 2 OR 3 CURB RAMPS  
(CALCULATE BASED ON NUMBER OF  
SETS OF DETECTABLE WARNING SURFACES)

NOTES:  
DETECTABLE WARNING SURFACE SHALL COVER 2'-0" LENGTH AND FULL WIDTH OF THE RAMP FLOOR AS SHOWN ON THE DETAILS.  
DETECTABLE WARNING SURFACE SHALL CONTRAST VISIBLY WITH ADJOINING SURFACE, EITHER LIGHT-ON-DARK, OR DARK-ON-LIGHT SEQUENCE COVERING THE ENTIRE RAMP.

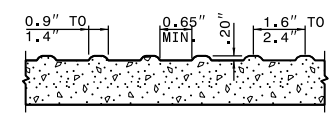
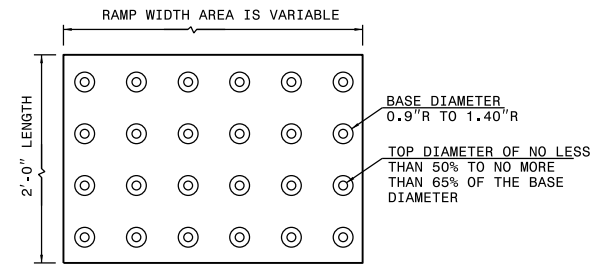

**DETECTABLE WARNING SURFACE**



NOTES:

1. CONSTRUCT THE RAMP SURFACE TO BE STABLE, FIRM, AND SLIP RESISTANT. CONSTRUCT THE CURB RAMP TYPE AS SHOWN IN THE PAVEMENT MARKING PLANS OR AS DIRECTED BY THE ENGINEER.
2. LOCATE CURB RAMPS AND PLACE PEDESTRIAN CROSSWALK MARKINGS AS SHOWN IN THE PAVEMENT MARKING PLANS. WHEN FIELD ADJUSTMENTS REQUIRE MOVING CURB RAMPS OR MARKINGS AS SHOWN, CONTACT THE SIGNING AND DELINEATION UNIT OR LOCATE AS DIRECTED BY THE ENGINEER.
3. COORDINATE THE CURB RAMP AND THE PEDESTRIAN CROSSWALK MARKINGS SO A 4'x4' CLEAR SPACE AT THE BASE OF THE CURB RAMP WILL FALL WITHIN THE PEDESTRIAN CROSSWALK LINES.
4. SET BACK DISTANCE FROM INSIDE CROSSWALK MARKING TO NEAREST EDGE OF TRAVEL LANE IS 4' MINIMUM.
5. REFER TO THE PAVEMENT MARKING PLANS FOR STOP BAR LOCATIONS AT SIGNALIZED INTERSECTIONS. IF A PAVEMENT MARKING PLAN IS NOT PROVIDED, CONTACT THE SIGNAL DESIGN SECTION FOR THE STOP BAR LOCATIONS OR LOCATE AS DIRECTED BY THE ENGINEER.
6. TERMINATE PARKING A MINIMUM OF 20' FROM THE BACK OF PEDESTRIAN CROSSWALK.
7. CONSTRUCT CURB RAMPS A MINIMUM OF 4' WIDE.
8. CONSTRUCT THE RUNNING SLOPE OF THE RAMP 8.33% MAXIMUM.
9. ALLOWABLE CROSS SLOPE ON SIDEWALKS AND CURB RAMPS WILL BE 2% MAXIMUM.
10. CONSTRUCT THE SIDE FLARE SLOPE A MAXIMUM OF 10% MEASURED ALONG THE CURB LINE.
11. CONSTRUCT THE COUNTER SLOPE OF THE GUTTER OR STREET AT THE BASE OF THE CURB RAMP A MAXIMUM OF 5% AND MAINTAIN A SMOOTH TRANSITION.
12. CONSTRUCT CLEAR SPACES FOR SIDEWALK A MINIMUM OF 4'x4' WITH A MAXIMUM SLOPE OF 2% IN ANY DIRECTION. CONSTRUCT CLEAR SPACES FOR MEDIAN ISLANDS A MINIMUM OF 5'x5' WITH A MAXIMUM SLOPE OF 2% IN ANY DIRECTION. IF CONSTRAINED ON TWO OR MORE SIDES, THE CLEAR SPACE SHALL BE 4' MINIMUM X 5' MINIMUM, WITH 5' PROVIDED IN THE DIRECTION OF THE PEDESTRIAN STREET CROSSING.
13. TO USE A MEDIAN ISLAND AS A PEDESTRIAN REFUGE AREA, MEDIAN ISLANDS WILL BE A MINIMUM OF 6' WIDE. CONSTRUCT MEDIAN ISLANDS TO PROVIDE PASSAGE OVER OR THROUGH THE ISLAND.
14. SMALL CHANNELIZATION ISLANDS THAT CAN NOT PROVIDE A 5'x5' CLEAR SPACE AT THE TOP OF RAMPS, WILL BE CUT THROUGH LEVEL WITH THE SURFACE STREET.
15. CURB RAMPS WITH RETURNED CURBS MAY BE USED ONLY WHERE PEDESTRIANS WOULD NOT NORMALLY WALK ACROSS THE RAMP, WHERE THE ADJACENT SURFACE IS PLANTING OR OTHER NON-WALKING SURFACE, OR THE SIDE APPROACH IS SUBSTANTIALLY OBSTRUCTED.
16. PLACE A 1/2" EXPANSION JOINT WHERE THE CONCRETE CURB RAMP JOINS THE CURB AS SHOWN IN ROADWAY STANDARD DRAWING 848.01.
17. PLACE ALL PEDESTRIAN PUSH BUTTON ACTUATORS AND CROSSING SIGNALS AS SHOWN IN THE PLANS OR AS SHOWN IN THE MUTCD.
18. DETECTABLE WARNING SURFACES WILL COVER 2'-0" LENGTH AND FULL WIDTH OF THE RAMP FLOOR AS SHOWN ON THE DETAILS.
19. DETECTABLE WARNING SURFACES WILL CONTRAST VISIBLY WITH ADJOINING SURFACE, EITHER LIGHT-ON-DARK, OR DARK-ON-LIGHT SEQUENCE COVERING THE ENTIRE RAMP.

1-24

ROADWAY STANDARD DRAWING FOR

**CURB RAMP**

NOTES

STATE OF

NORTH CAROLINA

DEPT. OF TRANSPORTATION

DIVISION OF HIGHWAYS

RALEIGH, N.C.

NOTES:

PLACE CONTRACTION JOINTS AT INTERVALS EQUAL TO THE WIDTH OF THE PATH.  $L=W$

CONSTRUCT JOINTS AT A DEPTH OF 1/4 OF THE SLAB THICKNESS.  $D=T/4$

DO NOT USE JOINT SEALANT FOR CONTRACTION JOINT CONSTRUCTION.

A 1/2" EXPANSION JOINT WILL BE REQUIRED WHERE THE CONCRETE SIDEPATH JOINS ANY RIGID STRUCTURE.

SEE STD. DWG. 848.05 FOR CURB RAMP LOCATION REQUIREMENTS AND CONSTRUCTION GUIDELINES.

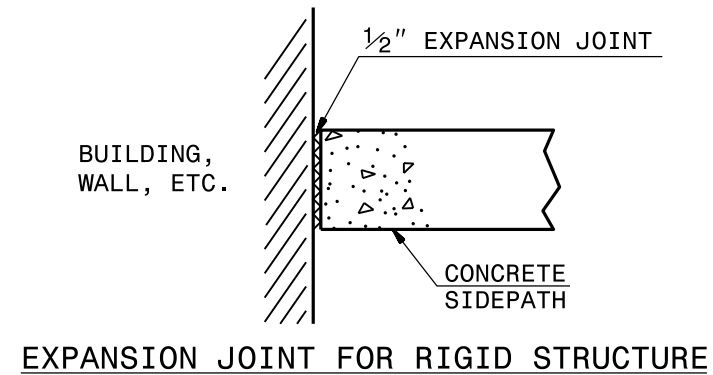
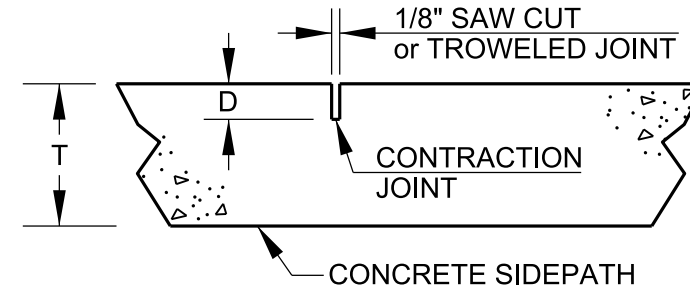
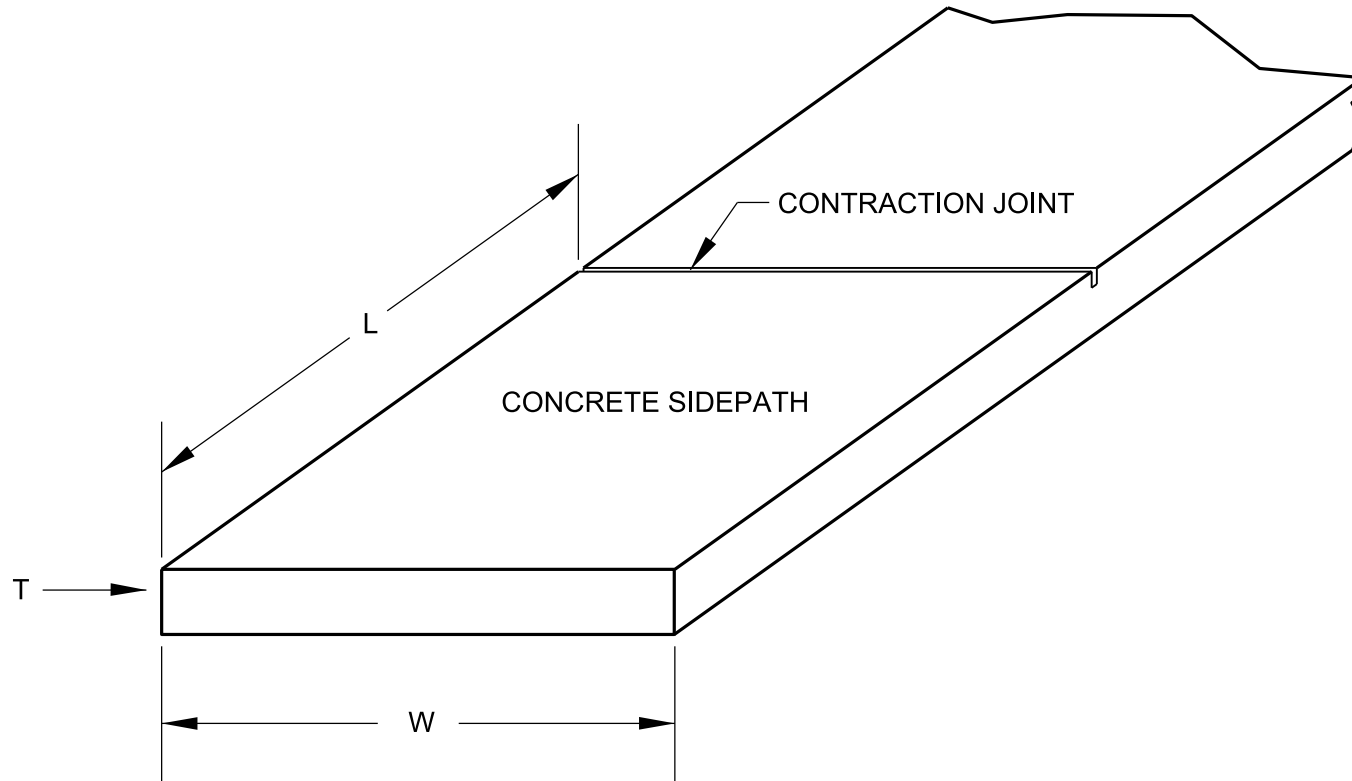

1-24 STATE OF NORTH CAROLINA DEPT. OF TRANSPORTATION DIVISION OF HIGHWAYS RALEIGH, N.C.

ROADWAY STANDARD DRAWING FOR  
**CONCRETE SIDEPATH/SHARED USE PATH/  
GREENWAY CONSTRUCTION**